



# Federal Register

---

**Tuesday,  
March 9, 2010**

---

## **Part III**

# **Department of Energy**

---

**10 CFR Part 431**

**Energy Conservation Program for Certain  
Commercial and Industrial Equipment:  
Test Procedure for Metal Halide Lamp  
Ballasts (Active and Standby Modes) and  
Proposed Information Collection, et al.;  
Final Rule and Notice**

## DEPARTMENT OF ENERGY

## 10 CFR Part 431

[Docket No. EERE-2008-BT-TP-0017]

RIN 1904-AB87

**Energy Conservation Program for Certain Commercial and Industrial Equipment: Test Procedure for Metal Halide Lamp Ballasts (Active and Standby Modes) and Proposed Information Collection; Comment Request; Certification, Compliance, and Enforcement Requirements for Consumer Products and Certain Commercial and Industrial Equipment; Final Rule and Notice**

**AGENCY:** Office of Energy Efficiency and Renewable Energy, Department of Energy.

**ACTION:** Final rule.

**SUMMARY:** The U.S. Department of Energy (DOE) is establishing metal halide lamp ballast test procedures in today's final rule by which manufacturers will demonstrate compliance with the metal halide lamp fixture energy conservation standards mandated by the Energy Policy and Conservation Act (EPCA), as amended. These test procedures are based primarily on and incorporate by reference provisions of American National Standards Institute (ANSI) Standard C82.6-2005, "Ballasts for High-Intensity Discharge Lamps—Methods of Measurement." As further required by EPCA, DOE is establishing a test method for measuring standby mode power consumption and explaining why off mode power consumption does not apply to metal halide lamp ballasts. The test procedures' standby mode provisions are based on the International Electrotechnical Commission (IEC) Standard 62301, "Household electrical appliances—Measurement of standby power." This rule also adopts a number of definitions for key terms.

**DATES:** These test procedures are effective on April 8, 2010. The incorporation by reference of a certain publication listed in this rule is approved by the Director of the Federal Register as of April 8, 2010.

**ADDRESSES:** You may review copies of all materials related to this rulemaking at the U.S. Department of Energy, Resource Room of the Building Technologies Program, 950 L'Enfant Plaza, SW., Suite 600, Washington, DC, (202) 586-2945, between 9 a.m. and 4 p.m., Monday through Friday, except Federal Holidays. Please call Ms. Brenda Edwards at the above telephone

number for additional information regarding visiting the Resource Room.

**FOR FURTHER INFORMATION CONTACT:** Ms. Linda Graves, U.S. Department of Energy, Office of Energy Efficiency and Renewable Energy, Building Technologies Program, Mailstop EE-2J, 1000 Independence Avenue, SW., Washington, DC 20585-0121. Telephone: (202) 586-1851. E-mail: [Linda.Graves@ee.doe.gov](mailto:Linda.Graves@ee.doe.gov).

For legal issues, contact Mr. Eric Stas, U.S. Department of Energy, Office of the General Counsel, GC-71, 1000 Independence Avenue, SW., Washington, DC 20585-0121. Telephone: (202) 586-9507. E-mail: [Eric.Stas@hq.doe.gov](mailto:Eric.Stas@hq.doe.gov).

**SUPPLEMENTARY INFORMATION:** This rule includes language that refers to the following standard that has been previously approved for incorporation by reference:

ANSI C82.6-2005, Proposed Revision of ANSI C82.6-1985 (ANSI C82.6), American National Standard for lamp ballasts—Ballasts for High-Intensity Discharge Lamps—Methods of Measurement, approved February 14, 2005.

Copies of this standard are available from: American National Standards Institute (ANSI), 25 W. 43rd Street, 4th Floor, New York, NY 10036, 212-642-4900, or go to <http://www.ansi.org>.

#### Table of Contents

- I. Authority and Background
- II. Summary of the Final Rule
- III. Discussion
  - A. Definitions
  - B. Test Method for Measuring Energy Efficiency of Metal Halide Lamp Ballasts
    - 1. Test Setup and Conditions
      - a. Lamp Orientation
      - b. Power Supply, Ambient Test Temperatures, and Instrumentation
      - c. Lamp Stabilization
    - 2. Test Measurements
    - 3. Ballast Efficiency Calculation
  - C. Test Method for Measuring Standby Power of Metal Halide Lamp Ballasts
    - 1. Overview of Test Method
    - 2. Test Method and Measurements
    - 3. Combining Measurements and Burden
  - D. Scope of Applicability of Standby Power Test Procedure
  - E. Effective Date of Standby Mode Test Method
  - F. Units To Be Tested
  - G. Submission of Data
  - H. Enforcement Provisions
  - I. Provisions for Compliance, Certification, and Enforcement
- IV. Procedural Issues and Regulatory Review
  - A. Review Under Executive Order 12866
  - B. Review Under the Regulatory Flexibility Act
  - C. Review Under the Paperwork Reduction Act of 1995
  - D. Review Under the National Environmental Policy Act

- E. Review Under Executive Order 13132
- F. Review Under Executive Order 12988
- G. Review Under the Unfunded Mandates Reform Act of 1995
- H. Review Under the Treasury and General Government Appropriations Act, 1999
- I. Review Under Executive Order 12630
- J. Review Under the Treasury and General Government Appropriations Act, 2001
- K. Review Under Executive Order 13211
- L. Review Under Section 32 of the Federal Energy Administration Act of 1974
- M. Congressional Notification
- V. Approval of the Office of the Secretary

#### I. Authority and Background

Title III of the Energy Policy and Conservation Act (42 United States Code (U.S.C.) 6291 *et seq.*; EPCA) sets forth provisions to improve energy efficiency. Part A<sup>1</sup> (42 U.S.C. 6291-6309) establishes the Energy Conservation Program for Consumer Products Other Than Automobiles (Program), which covers consumer products and certain commercial equipment, including metal halide lamp fixtures. (42 U.S.C. 6292(a)(19)) Metal halide lamp fixtures contain metal halide lamp ballasts. Because the metal halide lamp fixture energy conservation standards in EPCA establish a minimum efficiency for the ballasts incorporated into those fixtures, this test procedure addresses measurement of metal halide lamp ballast efficiency. (42 U.S.C. 6295(hh)(1)(A)).

The program generally includes testing, labeling, and Federal energy conservation standards. The testing requirements consist of test procedures prescribed under EPCA, that manufacturers of covered equipment must use: (a) As the basis for certifying to DOE that their products comply with energy conservation standards promulgated under EPCA; and (b) for representing the energy efficiency of their products. Similarly, DOE must use these test procedures when determining whether the equipment complies with energy conservation standards adopted pursuant to EPCA.

EPCA established generally applicable criteria and procedures for DOE's adoption and amendment of such test procedures (42 U.S.C. 6293), and provided that "[a]ny test procedures prescribed or amended under this section shall be reasonably designed to produce test results which measure energy efficiency, energy use, \* \* \* or estimated annual operating cost of a covered product during a representative average use cycle or period of use, as determined by the Secretary [of Energy],

<sup>1</sup> This part was originally titled Part B. It was redesignated Part A in the United States Code for editorial reasons.

and shall not be unduly burdensome to conduct.” (42 U.S.C. 6293(b)(3)).

For metal halide lamp ballasts, section 324(c) of the Energy Independence and Security Act of 2007 (Public Law (Pub. L.) 110–140; EISA 2007) amended EPCA and required DOE to establish test procedures for metal halide lamp ballasts—a newly covered equipment type under the statute—as follows: “(18) Metal halide lamp ballasts.—Test procedures for metal halide lamp ballasts shall be based on ANSI Standard C82.6–2005, titled ‘Ballasts for High-Intensity Discharge Lamps—Method of Measurement.’” (42 U.S.C. 6293(b)(18)).

Section 324(e) of EISA 2007 also prescribed mandatory minimum efficiency levels for pulse-start metal halide lamp ballasts, magnetic probe-start lamp ballasts, and nonpulse-start electronic lamp ballasts that operate [metal halide] lamps rated greater than or equal to 150 watts (W) but less than or equal to 500 W. (42 U.S.C. 6295(hh)(1)(A)) Excluded from these energy conservation standards are regulated lag ballasts,<sup>2</sup> electronic ballasts that operate at 480 volts, or ballasts in fixtures that are: (1) Rated only for 150 W lamps; (2) rated for use in wet locations, as specified by the National Electrical Code 2002, section 410.4(A); and (3) contain a ballast that is rated to operate at ambient air temperatures above 50 degrees Celsius (°C), as specified in UL 1029–2001 by Underwriters Laboratories, Inc. (42 U.S.C. 6295(hh)(1)(B)) These statutory standards apply to metal halide lamp fixtures manufactured on or after January 1, 2009. (42 U.S.C. 6295(hh)(1)(C)).

DOE again notes that because of the codification of the metal halide lamp fixture provisions in 42 U.S.C. 6295, a rulemaking for metal halide lamp fixture energy conservation standards and any associated test procedures are subject to the requirements of the consumer products provisions of Part A of Title III. However, because metal halide lamp fixtures (and their ballasts) are generally considered to be commercial equipment and consistent with DOE’s previous action to incorporate requirements of the Energy Policy Act of 2005 (EPACT 2005) for commercial equipment into 10 CFR part 431 (“Energy Efficiency Program for Certain Commercial and Industrial Equipment”), DOE intends to place the new requirements for metal halide lamp fixtures (and ballasts) in 10 CFR part

431 for ease of reference. DOE notes that the location of the provisions within the CFR does not affect either the substance or applicable procedure for metal halide lamp ballasts; as such, DOE is placing them in the appropriate CFR part based upon the nature or type of those products. Based upon their placement into 10 CFR 431, metal halide lamp ballasts will be referred to as “equipment” throughout this notice.

EISA 2007 further amended EPCA. In relevant part here, section 310 of EISA 2007 includes a requirement that DOE amend its test procedures, if technically infeasible, to include standby mode and off mode energy consumption in the overall energy efficiency, energy consumption, or other energy descriptor for each covered product for which DOE’s current test procedures do not fully account for standby mode and off mode energy consumption. If such combined measure is technically infeasible, DOE must prescribe a separate standby mode and off mode energy use test procedure, if technically feasible. (42 U.S.C. 6295(gg)(2)(A)) Any such amendment must consider the most current versions of IEC Standards 62301, “Household electrical appliances—Measurement of standby power,” and 62087, “Methods of measurement for the power consumption of audio, video and related equipment.” *Id.* Further, section 310 of EISA 2007 provides that any final rule establishing or revising energy conservation standards adopted on or after July 1, 2010, must incorporate standby mode and off mode energy use. (42 U.S.C. 6295(gg)(3)(A)) DOE notes here that EPCA, as amended, requires DOE to determine whether the energy conservation standards for metal halide lamp fixtures should be amended, and if so, DOE must publish a final rule with amended standards by January 1, 2012. (42 U.S.C. 6295(hh)(2)).

Accordingly, pursuant to section 310 of EISA 2007 and given the potential for amended energy conservation standards for metal halide lamp fixtures that address standby mode and off mode, DOE has concluded that its metal halide lamp ballast test procedure must account for standby mode and off mode energy consumption. (42 U.S.C. 6295(gg)(2)) A DOE test procedure is needed that accounts for standby mode and off mode energy use, in order to permit manufacturers to measure and certify compliance with energy conservation standards for metal halide lamp fixtures that address those modes. Today’s final rule will also provide DOE a means for determining compliance with any standard adopted for metal

halide lamp fixtures that includes such energy consumption.

## II. Summary of the Final Rule

As noted above, EPCA, as amended by EISA 2007, states that test procedures for metal halide lamp ballasts shall be based on ANSI Standard C82.6–2005 (ANSI C82.6–2005), “Ballasts for High Intensity Discharge Lamps—Methods of Measurement.” (42 U.S.C. 6293(b)(18)) DOE found ANSI C82.6–2005 suitable for testing metal halide lamp ballasts because it contained all of the required major elements to adequately measure the efficiency of metal halide lamp ballasts, as discussed in section III.B. Accordingly, DOE has drawn on relevant portions of ANSI C82.6–2005 in developing its metal halide lamp ballast test procedure. Specifically, today’s final rule references the ballast power loss measurement method (section 6.10) of ANSI C82.6–2005 as the means of determining the efficiency of metal halide lamp ballasts, and references other applicable sections of ANSI C82.6–2005 for test conditions and setup. The test procedure currently applies to metal halide lamp ballasts that operate lamps rated greater than or equal to 150 W but less than or equal to 500 W (although it is capable of measuring ballasts operating lamps of both higher and lower wattage ranges), and the final rule establishes test methodologies for measuring standby mode power consumption, based on relevant portions of IEC 62301 and ANSI C82.6–2005. Finally, the final rule establishes the sampling and efficiency calculations to be used.

DOE reviewed the definitions of “standby mode” and “off mode” contained in EPCA section 325(gg)(1) in the context of metal halide lamp ballasts. (42 USC 6295(gg)(1)) DOE found that, while it is possible for metal halide lamp ballasts to operate in standby mode, the off mode condition does not apply because it addresses a mode of energy use in which metal halide lamp ballasts do not operate. For this reason, today’s final rule prescribes a test method for measuring power consumption in standby mode (section III.C), but it does not prescribe an off mode test method. The prescribed standby mode test will enable DOE to consider and address standby mode energy consumption in the next metal halide lamp fixture energy conservation standards rulemaking.

The “standby mode” definition established by EISA 2007 does not apply to all ballasts. 74 **Federal Register** (FR) 33171, 33174 (July 10, 2009). There are two types of ballasts (*i.e.*, magnetic and electronic), but only electronic

<sup>2</sup> A “regulated lag ballast” is the industry term for a lag ballast with a third coil for improved lamp power regulation.

ballasts or magnetic ballasts operating with an auxiliary control device can operate in standby mode. DOE determined that standby mode applies only to certain ballasts under certain operating conditions. See sections III.A. and III.C for a detailed discussion of the definitions for “standby mode” and “off mode,” as well as test methods for standby mode.

As provided by EPCA, amendments to the test procedures to include standby mode and off mode energy consumption shall not be used to determine compliance with previously established standards. (42 U.S.C. 6295(gg)(2)(C)) The inclusion of a standby mode test method in this final rule will not affect a manufacturer’s ability to demonstrate compliance with the energy conservation standards for metal halide lamp fixtures that took effect January 1, 2009. (42 U.S.C. 6295(hh)(1)(C)(i)) The standby mode test need not be performed to determine compliance with the current energy conservation standards for metal halide lamp fixtures because the standards do not account for standby mode energy consumption.

Today’s final rule, which includes provisions for measuring standby mode, will become effective, in terms of adoption into the Code of Federal Regulations (CFR), 30 days after the date of publication in the **Federal Register**. Manufacturers will be required to use this test procedure’s standby mode provisions to demonstrate compliance with any future energy conservation standards for metal halide lamp fixtures as of the effective date of a final rule establishing amended energy conservation standards for metal halide lamp fixtures that address standby mode energy consumption. The introductory sentence in section 431.324(c) reads as follows: “The measurement of standby mode need not be performed to determine compliance with energy conservation standards for metal halide lamp fixtures at this time. The above statement will be removed as part of the rulemaking to amend the energy conservation standards for metal halide lamp fixtures to account for standby mode energy consumption, and the following shall apply on the compliance date for such requirements.” The quoted language will be removed in the rulemaking to amend the EISA 2007 energy conservation standards for metal halide lamp fixtures to address standby mode power consumption. A statement has also been added at 10 CFR 431.324(c) to clarify that on or after a date 180 days after the date of publication on this final rule, any representations pertaining to standby mode energy consumption must be

based upon testing under the relevant provisions of this test procedure. Although this is a statutory requirement under 42 U.S.C. 6293(c)(2), DOE has concluded that it would be useful to explicitly state this requirement in DOE’s regulations.

### III. Discussion

Before addressing specific technical comments on the metal halide lamp ballast test procedure notice of proposed rulemaking (NOPR), DOE would first summarize its general approach to this rulemaking and address one related comment. In the July 10, 2009 NOPR, DOE proposed that only the active mode and standby mode applied to metal halide lamp ballasts, and tentatively concluded that off mode is not applicable. 74 FR 33171, 33172–73 (July 10, 2009). For the NOPR, DOE also reviewed ANSI C82.6–2005 to determine whether any additional elements would be needed to provide a complete test procedure, and tentatively concluded that all elements required for conducting efficiency measurements of metal halide lamp ballasts are present in ANSI C82.6–2005, including lamp orientation, power supply characteristics, operational test temperatures, instrumentation requirements, setup connections, and lamp stabilization. In the NOPR, DOE also discussed the ANSI standards development process. *Id.* at 33173. DOE affirms these tentative conclusions in today’s final rule. Accordingly, after carefully considering and addressing comments on the NOPR, DOE is adopting the applicable requirements and methods of ANSI C82.6–2005 into the DOE test procedure for metal halide lamp ballasts. In addition, DOE adopts a statistically meaningful method for determining sample size as part of the metal halide lamp ballast test procedure, consistent with the sampling plans used in other DOE test procedures.

The National Electrical Manufacturers Association (NEMA) informed DOE that ANSI C82.6–2005 is in the process of being revised, and suggested that DOE or its contractors participate in the standards development process. (NEMA, Public Meeting Transcript, No. 11 at p. 8) DOE appreciates this comment and understands the context for NEMA’s suggestion. Although DOE is supportive of the ANSI standard-setting process and DOE (or its contractor) may consider participation in that standards process, DOE is unable to use a different version of C82.6–2005 at this time for two reasons: (1) DOE is directed by the statute to base its test procedure on the 2005 edition of ANSI

C82.6 for determining the efficiency of metal halide lamp ballasts used in metal halide lamp fixtures (42 U.S.C. 6293(b)(18)); and (2) DOE needs to adopt a test procedure for metal halide lamp ballasts to address the current, statutorily-prescribed standards for ballasts contained in metal halide lamp fixtures. DOE further notes that ANSI C82.6–2005 is still active and is the most current version of this test procedure. DOE is concerned that postponing this test procedure rulemaking to wait for the updated version of ANSI C82.6 to be issued could cause a significant delay in adoption of a test procedure for metal halide lamp ballasts. If industry does issue an revised version of ANSI C82.6, DOE may update today’s adopted test procedure when it considers amendments as required by section 323(b)(1)(A) of EPCA. (42 U.S.C. 6293(b)(1)(A))

#### A. Definitions

DOE reviewed the relevant portions of EISA 2007 and 10 CFR part 431 for applicable existing definitions for use in developing and applying the metal halide lamp ballast test procedure. EISA 2007 amends EPCA, in part, by adding definitions of key terms that are applicable to the metal halide lamp ballast test procedure, including “ballast,” “ballast efficiency,” “electronic ballast,” “metal halide lamp ballast,” “metal halide lamp,” “metal halide lamp fixture,” “probe-start metal halide lamp ballast,” and “pulse-start metal halide lamp ballast.” (42 U.S.C. 6291) These definitions were set forth in the July 10, 2009 NOPR. 74 FR 33171, 33173–74. DOE discusses the terms “ballast,” “ballast efficiency,” and “electronic ballast” below, for which it codifies new or revised definitions in today’s final rule. The other terms, including “metal halide lamp ballast,” “metal halide lamp,” “metal halide lamp fixture,” “probe-start metal halide lamp ballast,” and “pulse-start metal halide lamp ballast” were previously inserted into the CFR by the Technical Amendment Final Rule and remain unchanged. 74 FR 12058, 12075–76 (March 23, 2009). “Ballast”

EISA 2007 provides a new definition for the term “ballast” which is relevant to metal halide lamp fixtures. This term is defined as follows: “a device used with an electric discharge lamp to obtain necessary circuit conditions (voltage, current, and waveform) for starting and operating. (42 U.S.C. 6291(58)) This definition was already adopted into DOE’s regulations for both consumer products (10 CFR 430.2) and

commercial equipment (10 CFR 431.282) in the Technical Amendment Final Rule. 74 FR 12058, 12064 (March 23, 2009). However, DOE is adopting this definition into 10 CFR 431.322 without modifications in today's final rule.

#### "Ballast Efficiency"

EISA 2007 also provides a definition for the term "ballast efficiency" which is relevant to metal halide lamp fixtures. (42 U.S.C. 6291(59)) This term was adopted by DOE in the Technical Amendment Final Rule (74 FR 12058, 12075 (March 23, 2009)) as follows: "in the case of a high-intensity discharge fixture, the efficiency of a lamp and ballast combination, expressed as a percentage." Ballast efficiency is calculated in accordance with the formula presented with the definition for the term "ballast efficiency" in the Technical Amendment Final Rule (74 FR 12075, March 23, 2009).

In its comments on the NOPR, NEMA recommended that the frequency referenced in the definition of "ballast efficiency" be increased from 2 kHz to 2.4 kHz, which includes the 40th order of the total harmonic for frequencies greater than 60 Hz. (NEMA, No. 21 at p. 4) DOE considered this comment, and reviewed other related similar test methods for related lighting products. DOE found that ANSI C82.77-2002, "American National Standard for Harmonic Emission Limits-Related Quality Requirements for Lighting Equipment," requires harmonic measurements up to the 40th harmonic. DOE also recognizes that to increase the frequency and include the 40th harmonic will improve the accuracy and repeatability of the test method adopted for metal halide lamp ballasts, thereby resulting in an improvement in the test procedure overall. For all of these reasons, DOE accepts NEMA's recommendation to extend ballast efficiency measurement to 2.4 kHz, and has amended the definition adopted in today's final rule accordingly.

#### "Electronic Ballast"

EISA 2007 provides a definition for the term "electronic ballast" which is relevant to metal halide lamp fixtures. This term is defined as follows: "a device that uses semiconductors as the primary means to control lamp starting and operation." (42 U.S.C. 6291(60)) This definition was already adopted into DOE's regulations for consumer products (10 CFR 430.2) in the Technical Amendment Final Rule. 74 FR 12058, 12065 (March 23, 2009). However, DOE is adopting this definition into 10 CFR 431.322 without

modification in today's final rule. As stated in its NOPR, DOE notes that it interprets this definition to include equipment commonly referred to as "nonpulse-start electronic ballasts." 74 FR 33171, 33173 (July 10, 2009). DOE notes that this interpretation is by no means limited to such ballasts, and that other types of electronic ballasts such as "pulse-start electronic ballasts" would fall under this statutory definition.

#### "Basic Model"

In addition to the terms discussed above, in today's final rule, DOE is amending 10 CFR 431.322, "Definitions concerning metal halide lamp ballasts and fixtures," by adding a definition for "basic model" as it relates to metal halide lamp ballasts. DOE is also inserting definitions for terms associated with the measurement of standby mode power consumption for metal halide lamp ballasts. These terms are "active mode," "standby mode," "off mode," "alternating current (AC) control signal," "direct current (DC) control signal," "power line carrier (PLC) control signal," and "wireless control signal." It should be noted that the statute provides definitions for three modes of energy consumption (*i.e.*, active, standby, and off modes) that are applicable to a broad set of consumer products and commercial equipment, including metal halide lamp ballasts. (42 U.S.C. 6295(gg)(1)(A)) DOE adopts definitions for the terms "active mode," "standby mode," and "off mode" in today's final rule.

In the NOPR, DOE proposed a definition for a metal halide lamp ballast "basic model" at 10 CFR 431.322 based on the existing "basic model" definition for a fluorescent lamp ballast at 10 CFR 430.2. 74 FR 33171, 33174 (July 10, 2009). The proposed definition of the term "basic model" reads as follows: "with respect to metal halide [lamp] ballasts, as all units of a given type of metal halide [lamp] ballast (or class thereof) that: (1) Are rated to operate a given lamp type and wattage; (2) Have essentially identical electrical characteristics; and (3) Have no differing electrical, physical, or functional characteristics that affect energy consumption." *Id.* at 33184. DOE did not receive any comments on this proposed definition, and, therefore, is adopting it in today's final rule without substantive modification.

#### "Active Mode"

In the NOPR, DOE proposed to adopt the statutory definition for "active mode" as it applies to metal halide lamp ballasts. EPCA defines "active mode" as "the condition in which an energy-using

product—(I) is connected to a main power source; (II) has been activated; and (III) provides 1 or more main functions." (42 U.S.C. 6295(gg)(1)(A)(i)) In the NOPR, DOE stated that the main function of the metal halide lamp ballast is to operate one or more metal halide lamps (*i.e.*, starting the lamp and regulating the current, voltage, or power of the lamp). DOE also stated that there are many different types of ballasts that could be considered "metal halide lamp ballasts," but the main function common to all of them is that they are designed to operate metal halide lamps. DOE did not discriminate between non-dimmable<sup>3</sup> and dimmable<sup>4</sup> ballasts when considering active mode; rather, DOE interprets active mode as being applicable to any amount of rated system light output (*i.e.*, greater than zero percent of the rated system light output). 74 FR 33171, 33174 (July 10, 2009). DOE received a comment from NEMA on this initial interpretation. NEMA requested that the term "active mode" be defined as operation of a metal halide lamp ballast at 100 percent of rated power. (NEMA, No. 21 at p. 4) DOE considered this comment, but is unable to adopt NEMA's proposed revision to the definition of "active mode." DOE's view that active mode applies to a functioning ballast operating with any amount of rated system light output (*i.e.*, greater than zero percent) has not changed (however, see the "fault load" discussion immediately below), and no new information has been introduced by the commenter that would cause DOE to adopt the commenter's suggested interpretation of "active mode." If a ballast is dimming (operating the light source greater than zero percent, but less than 100 percent) the lamp and the ballast are both still in active mode.

Although DOE did not address this condition in the NOPR, DOE wishes to clarify that a ballast connected to a fault load (*i.e.*, a lamp that is no longer working) is considered by DOE to be in active mode. In this mode, the ballast meets all three criteria for active mode function. The ballast is: (1) Connected to a main power source; (2) activated; and (3) providing its main function, which is to apply a voltage across the sockets in an attempt to start and operate a lamp. Therefore, active mode for metal halide lamp ballasts is considered to be the condition in which the ballast provides either: (1) A regulated current

<sup>3</sup> Non-dimmable ballasts would operate the lamp or lamps in active mode at 100 percent of the rated system light output.

<sup>4</sup> Dimmable ballasts may vary the system light output from 100 percent to some lower level of light output, either in steps or continuously.

to a properly-installed functional lamp; or (2) a voltage to the sockets to start and operate a lamp if a functional lamp were properly installed. DOE no longer believes that a ballast is in active mode only when the light output is any percentage greater than zero of the rated system light output because such a definition presupposes that a functional lamp is properly installed. Although, DOE is changing its interpretation of active mode, DOE's interpretation of standby mode and off mode remain the same as in the January 2009 NOPR. 74 FR 33171, 33174–75 (July 10, 2009). Furthermore, the interpretation of active mode in this final rule is consistent with other DOE interpretations for similar types of equipment and products (*i.e.*, ballasts). DOE had this same interpretation in the fluorescent lamp ballast standby test procedure 74 FR 54445, 54447 (Oct. 22, 2009).

#### “Standby Mode”

“Standby mode” is defined under EPCA as “the condition in which an energy-using product—(I) is connected to a main power source; and (II) offers 1 or more of the following user-oriented or protective functions: (aa) To facilitate the activation or deactivation of other functions (including active mode) by remote switch (including remote control), internal sensor, or timer. (bb) Continuous functions, including information or status displays (including clocks) or sensor-based functions.” (42 U.S.C. 6295(gg)(1)(A)(iii)) As discussed below, two key aspects of this definition relate to metal halide lamp ballasts: (1) Connected to a main power source; and (2) offering the activation or deactivation of other functions by remote switch or internal sensor.

The definition of “standby mode” in part requires that ballasts be connected to their main power source. (42 U.S.C. 6295(gg)(1)(A)(iii)(I)) This “connected” requirement effectively precludes the majority of ballasts from having standby mode energy consumption, because most ballasts are operated with on-off switches, circuit breakers, or other relays that disconnect the ballast from the main power source. Although further consideration of such ballasts is unnecessary because their operational design falls outside the statutory definition of “standby mode,” DOE would characterize their operation in such situations as follows: Once the ballast is disconnected from the main power source, the ballast ceases to operate the lamp, and the ballast consumes no energy. The vast majority of metal halide lamp ballasts do not consume power when they are switched

off. Based on the statutory definition of “standby mode,” ballasts controlled by disconnecting the ballast from the main power source do not operate in standby mode.

The “standby mode” definition further states that it applies to energy-using products that facilitate the activation or deactivation of other functions by remote switch, internal sensor, or timer. (42 U.S.C. 6295(gg)(1)(A)(iii)(II)(aa)) DOE interprets this condition as applying to ballasts that are designed to operate in or function as a lighting control system where auxiliary control devices send signals. An example of this type of ballast would be one that incorporates a digital addressable lighting interface (DALI) capability. Regardless of dimming, these ballasts incorporate an electronic circuit that enables the ballast to communicate with, and receive orders from, the DALI system. These instructions could tell the ballast to go into active mode or to adjust the light output to zero percent output. In this latter condition, the ballast no longer provides current to the metal halide lamp (*i.e.*, no longer in active mode). Thus, at zero light output, the ballast is standing by, connected to a main power source while it awaits instructions from the lighting control system to initiate an arc so the metal halide lamp can produce light again. Another example would be a metal halide lamp ballast that incorporates a lighting control circuit connected to a photosensor. This ballast and sensor function as a miniature lighting controls system, where the sensor provides input to the ballast control circuit, which determines whether the lamp should be operational. When the lamp is not operational (*i.e.*, when the photosensor indicates that it is bright outside), the ballast will consume power to enable the photosensor circuit to monitor the ambient conditions. When the circuit determines that the ambient conditions are sufficiently dark to start the lamp, it will instruct the ballast to initiate an arc in the lamp.

In its comments on the NOPR, NEMA accepted DOE's interpretation and application of standby mode to metal halide lamp ballasts that incorporate a circuit to enable the ballast to communicate with lighting control systems. (NEMA, No. 21 at p. 4) However, NEMA requested that the term “standby mode” be further defined to clarify that a stand-alone magnetic metal halide lamp ballast that does not incorporate any auxiliary electronic control devices be exempt from any energy consumption measurements in standby mode. (NEMA, No. 21 at p. 4) DOE considered this comment, but has

not made any change to the definition of “standby mode” for two principal reasons. First, as DOE stated in the NOPR and again reiterates in this final rule, it is interpreting standby mode as only being applicable to ballasts that connect to lighting control systems via circuits that allow for communication with the control system. This interpretation is valid, regardless of the type of ballast (*e.g.*, magnetic, electronic). If the magnetic ballast does not have the circuit (in this case, an auxiliary electronic control device), then the ballast would not be considered capable of operating in standby mode. Second, DOE does not understand why one type of ballast should be singled out in the definition of the term “standby mode,” to the exclusion of others, in order to establish that ballast type as exempt. Inserting language like this into the definition could be interpreted as providing uneven treatment of the various types of ballasts with respect to the definition of “standby mode.” Given that there are other types of metal halide lamp ballasts in addition to the magnetic type, this explicit mention might confuse interested parties as to the applicability of standby mode for metal halide lamp ballasts overall.

#### “Off Mode”

As DOE discussed in the NOPR, “off mode” is defined by EPCA as “the condition in which an energy-using product—(I) is connected to a main power source; and (II) is not providing any standby or active mode function.” (42 U.S.C. 6295(gg)(1)(A)(ii)) In the NOPR, DOE considered this definition in the context of metal halide lamp ballasts and stated that it believes that off mode does not apply to any metal halide lamp ballast, dimmable or non-dimmable, because off mode describes a condition that commercially-available ballasts do not attain. 74 FR 33171, 33174–75 (July 10, 2009). The definition of “off mode” requires that ballasts be connected to a main power source and not provide any standby mode or active mode function. (42 U.S.C. 6295(gg)(1)(A)(ii)) It is not possible for ballasts to meet these criteria, because there is no condition in which the ballast is connected to the main power source and is not in a mode already accounted for in either active mode or standby mode (as defined previously). Thus, ballasts never meet the second requirement of the EPCA definition of “off mode.” (42 U.S.C. 6295(gg)(1)(A)(ii)(II)) NEMA commented that they accept the DOE approach for assessing metal halide lamp ballast operation in active mode and standby

mode. NEMA also agreed that “off mode” does not apply to metal halide lamp ballasts and should not be included as part of the proposed test procedure. (NEMA, No. 21 at p. 4) Therefore, for the reasons above, DOE’s interpretation of “off mode” remains the same as in the NOPR, namely, DOE has concluded that off mode is not applicable to metal halide lamp ballasts. 74 FR 33171, 33175 (July 10, 2009). Should circumstances change, DOE may revisit this interpretation and propose a test method in a future rulemaking for measuring off mode in metal halide lamp ballasts.

#### “AC Control Signal”

In the NOPR, DOE proposed a definition for the term “AC control signal.” 74 FR 33171, 33175 (July 10, 2009). In its study of the market, DOE found that some lighting control systems operate by communicating with (*i.e.*, providing a control signal to) lamp ballasts over a separate wiring system using AC voltage. DOE was unable to locate a definition for “AC control signal” in International Electrotechnical Commission (IEC) 62301 or ANSI C82.6–2005. Therefore, DOE proposed a definition for an “AC control signal” in its NOPR to enhance the clarity and understanding of its test procedure. 74 FR 33171, 33175 (July 10, 2009). NEMA commented that they accepted the proposed definition by DOE for “AC control signal.” (NEMA, No. 21 at p.4) Given the absence of negative comment, DOE is adopting a definition for “AC control signal” as follows: “an alternating current (AC) signal that is supplied to the ballast using additional wiring for the purpose of controlling the ballast and putting the ballast in standby mode.”

#### “DC Control Signal”

In the NOPR, DOE proposed a definition for the term “DC control signal.” 74 FR 33171, 33175 (July 10, 2009). In its study of the market, DOE found that some lighting control systems operate by communicating with (*i.e.*, providing a control signal to) the lamp ballasts over a separate wiring system using DC voltage. DOE was unable to locate a definition for “DC control signal” in IEC 62301 or ANSI C82.6–2005. Therefore, DOE proposed a definition for a “DC control signal” in its NOPR to enhance the clarity and understanding of its test procedure. 74 FR 33171, 33175 (July 10, 2009). NEMA commented that it accepted DOE’s proposed definition for “DC control signal.” (NEMA, No. 21 at p.4) DOE received no dissenting comments to its proposed definition, and, therefore, is

adopting the following definition for “DC control signal” as “a direct current (DC) signal that is supplied to the ballast using additional wiring for the purpose of controlling the ballast and putting the ballast in standby mode.”

#### “Power Line Carrier (PLC) Control Signal”

In the NOPR, DOE proposed a definition for the term “power line carrier (PLC) control signal.” 74 FR 33171, 33175 (July 10, 2009). In its study of the market, DOE found that some lighting control systems operate by communicating with (*i.e.*, providing a control signal to) the lamp ballasts over the existing power lines that provide the main power connection to the ballast. DOE was unable to locate a definition for “PLC control signal” in IEC 62301 or ANSI C82.6–2005. Therefore, DOE proposed a definition for a “PLC control signal” in its NOPR to enhance the clarity and understanding of its test procedure. 74 FR 33171, 33175 (July 10, 2009). NEMA commented that it accepted DOE’s proposed definition for “PLC control signal.” (NEMA, No. 21 at p. 4) DOE received no dissenting comments to its proposed definition, and, therefore, is adopting the following definition for “PLC control signal” as “a power line carrier (PLC) signal that is supplied to the ballast using the input ballast wiring for the purpose of controlling the ballast and putting the ballast in standby mode.”

#### “Wireless Control Signal”

In the NOPR, DOE proposed a definition for the term “wireless control signal.” 74 FR 33171, 33175 (July 10, 2009). In its study of the market, DOE found that some lighting control systems operate by communicating with (*i.e.*, providing a control signal to) the lamp ballasts over a wireless system, much like a wireless computer network. DOE was unable to locate a definition for a “wireless control signal” in IEC 62301 or ANSI C82.6–2005. Therefore, DOE proposed a definition for a “wireless control signal” in the July 2009 NOPR to enhance the clarity and understanding of its test procedure. 74 FR 33171, 33175 (July 10, 2009). NEMA commented that it accepted DOE’s proposed definition for “wireless control signal.” (NEMA, No. 21 at p. 4) DOE received no dissenting comments to its proposed definition, and, therefore, is adopting the following definition for “wireless control signal” as “a wireless signal that is radiated to and received by the ballast for the purpose of controlling the ballast and putting the ballast in standby mode.” In today’s final rule,

DOE is not requiring measurement of the power consumed by the ballast through the wireless control signal, because the quantity of power contained in the signal is extremely small (on the order of milliwatts), would be difficult to measure, and is unlikely to appreciably affect ballast power consumption.

#### *B. Test Method for Measuring Energy Efficiency of Metal Halide Lamp Ballasts*

##### 1. Test Setup and Conditions

###### a. Lamp Orientation

In the NOPR, DOE proposed to require that lamp orientation for testing be as specified in section 4.3 of ANSI C82.6–2005, which requires vertical, base-up orientation, unless the manufacturer specifies another orientation for that ballast and associated lamp combination. 74 FR 33171, 33176 (July 10, 2009). DOE proposed the base-up orientation, unless the manufacturer specifies another orientation approach for two reasons: (1) Vertical, base-up lamp orientation is the most common in the industry; and (2) the natural stability of the vertical operating position would produce the most repeatable and accurate testing results. PG&E commented during the public meeting that in response to efforts to advocate for improved efficiency for horizontal-burned lamps in California, the industry argued that horizontally-oriented lamps are significantly different products than vertically-oriented products and, thus, need to be treated differently. PG&E raised concerns about measuring the ballast efficiency of ballasts operating horizontally-oriented lamps as compared to more common vertically-oriented lamps. (PG&E, Public Meeting Transcript, No. 11, at p. 11) NEMA also commented on lamp orientation during the public meeting, stating that a uniform test set-up is important. However, NEMA argued that; the ballast is the key to measuring ballast efficiency, not lamp orientation. (NEMA, Public Meeting Transcript, No. 11 at p. 12)

NEMA agreed with using section 4.3 of ANSI C82.6–2005 that specifies vertical, base-up orientation unless specifically designed for another position. (NEMA, No. 21 at p. 3) PG&E was supportive after learning that the default lamp orientation is vertical but if the lamp is designed to be operated in a non-vertical position, it shall be tested in this orientation. (NEMA, Public Meeting Transcript, No. 11 at p. 12) With the support of comments from these two interested parties, DOE



maintains that operating the lamp in a vertical, base-up orientation is the most stable in terms of operation of the lamp, and that the lamp operation directly corresponds to the power input of the lamp (power output of the ballast). Therefore, operating the lamp in the most stable orientation is essential for repeatable and reliable measurement of metal halide lamp ballast efficiency. DOE adopts the requirement that ballast efficiency tests be conducted with metal halide lamps in a vertical, base-up orientation unless the manufacturer specifies another orientation for that ballast and associated lamp combination.

#### b. Power Supply, Ambient Test Temperatures, and Instrumentation

In the NOPR, DOE proposed that power supply characteristics, ambient test temperatures, and instrumentation requirements would all be as specified in section 4.0 of ANSI C82.6–2005. 74 FR 33171, 33176 (July 10, 2009). DOE recognizes that specification of objective test setup characteristics is an important consideration in terms of producing reliable, repeatable, and consistent test results. These aspects of DOE's NOPR and interested party response to them are discussed below.

Section 4.1 of ANSI C82.6–2005 requires that the root mean square (RMS) summation of harmonic components in the power supply be no more than 3 percent of the fundamental voltage and frequency components. Section 4.1 also requires that: (1) The impedance of the power source be no more than 3 percent of the specified ballast impedance; and (2) power supply devices used in the test circuits have a power rating at least five times the wattage of the lamp intended to operate on the ballast under test. These requirements provide reasonable stringency in terms of power quality because they are consistent with other comprehensive industry standards that regulate harmonic content and power supply impedance (e.g., ANSI C78.389–2004). Furthermore, these requirements would be readily achievable and would likely ensure repeatable and consistent measurements. During the December 2008 public meeting, NEMA commented that the requirement for impedance to the power source proposed by the test procedure of no more than 3 percent was too high. (NEMA, Public Meeting Transcript, No. 11 at p. 12) However, NEMA did not provide any rationale to explain its opinion, nor did it provide any supporting data. No additional information was received on this topic during the comment period. Therefore,

DOE has not changed its position with respect to the impedance of the power source. Consequently, DOE is adopting the requirement as proposed in the NOPR.

Section 4.2 in ANSI C82.6–2005 requires maintenance of an ambient temperature of 25 °C ±5 °C to reduce potential ballast operating variances caused by large shifts in ambient temperature. Although ambient temperature is not considered critical to metal halide lamp operation and light output, it can affect lamp and ballast system electrical performance. Therefore, temperatures must be controlled for ballast efficiency testing to ensure repeatability and consistency of test results. In the NOPR, DOE also proposed to require that testing be performed in a draft-free environment. 74 FR 33171, 33176 (July 10, 2009). DOE's proposed requirement acknowledged common industry practices whereby airflow is minimized near photometric testing equipment (e.g., through vent and air return locations, baffling of vents, and/or control of blower speed) in order to minimize forced convection cooling that could affect measured photometric and electrical data. NEMA noted that some movement of air is needed to prevent thermal stratification near the testing equipment, but acknowledged that airflow should be minimized. (NEMA, Public Meeting Transcript, No. 11 at p. 14) In response to DOE's proposal, NEMA stated that because current industry standards specify no requirement for draft-free conditions, DOE needs to provide a suitable reference on the conditions of a draft-free environment. NEMA commented further that if no definition is available, then the thermal test methods of C82.6–2005 should be strictly applied, and this reference to a draft-free environment should be removed from the document. (NEMA, No. 21 at p. 1) DOE considered these comments and again reviewed the technical literature on this topic, finding that:

1. Section 4.2, *Ballast Conditions*, of ANSI C82.6–2005 states, "For normal operational tests, the ambient temperature and the temperature of the ballast under test shall be 25 °C ±5 °C." DOE acknowledges that ANSI C82.6–2005 sets the temperature requirement, but not the air movement requirement. However, ANSI C82.6–2005 lists 12 references in section 2.0 *Normative References* that, by their inclusion, are considered indispensable for application of the ANSI standard. DOE reviewed all of the normative references contained in ANSI C82.6–2005 and identified the references that are

applicable to metal halide ballasts and lamps, as listed below by ANSI citation and not chronologically by date of publication.

a. ANSI C78.43–2004, "Single-Ended Metal-Halide Lamps," is applicable to this test procedure since it relates to metal halide lamps. Section 5.6.2, *Warm-up Time*, states, "A bare lamp operating in still air at an ambient temperature 25 °C ±5 °C (77 °C ±9 °C) under the conditions described in ANSI C78.389 shall reach the minimum voltage within the time period specified on the relevant data sheet." Other temperature and air conditions are considered in section 6.7, *Lamp Operating Wattage*, which states "The operating wattage of a bare lamp, measured in its designated operating position on a ballast throughout its range of rated supply voltages in a still air ambient temperature of 25 °C ±5 °C (77 °C ±9 °C), shall remain within the wattage limits of the relevant lamp data sheet. Lamps shall operate within these limits throughout the full range of lamp voltage tolerance." (It is noted that in 2007, ANSI C78.43 was updated; however, the temperature and airflow provisions at issue here did not change in ANSI C78.43–2007.)

b. ANSI C78.389–2004, "High-Intensity Discharge—Methods of Measuring Characteristics," section 3.3, *Ambient Condition*, states, "The ambient [condition] in which the lamp is operated shall be maintained at 25 °C ±5 °C and shall be draft-free."

c. ANSI C82.4–2002, "Ballasts for High-Intensity Discharge and Low Pressure Sodium Lamps," does not include any information regarding airflow.

d. ANSI C82.9–1996, "Definitions for High-Intensity Discharge and Low Pressure Sodium Lamps, Ballasts, and Transformer," does not mention and, therefore, does not define "still air" or "draft free."

2. Section 4.2, *Test Room*, of IEC 62301 states that, "The tests shall be carried out in a room that has an air speed close to the appliance under test of ≤ 0.5 m/s. The ambient temperature shall be maintained at (23±5) °C throughout the test. Note: The measured power for some products and modes may be affected by the ambient conditions (e.g., illuminance, temperature)."

3. DOE examined different Illuminating Engineering Society of North America's (IESNA) Lighting Measurement (LM) documents that focus on photometric and electrical measurements of either HID lamps or HID luminaires. DOE's review of applicable IESNA documents is listed



below by LM citation and not chronologically by date of publication.

a. IESNA LM-31-95, "Photometric Testing of Roadway Luminaires Using Incandescent Filament and High Intensity Discharge Lamps," states in section 4.1.3, *Special Photometer Calibration*, "Calibration of HID lamps shall be performed in relatively draft free air at ambient temperature of 25 °C (77 °F) ±5 °C (9 °F)."

b. IESNA LM-35-02, "IESNA Approved Method for Photometric Testing of Floodlights Using High Intensity Discharge or Incandescent Filament Lamps," states in section 3.2, *Ambient Temperatures*, "The ambient temperature of the photometric laboratory shall be maintained at 25 °C ±5 °C (77 °F ±9 °F)." There is no mention of airflow in LM-35-02.

c. IESNA LM-46-04, "IESNA Approved Method for Photometric Testing of Indoor Luminaires Using High Intensity Discharge or Incandescent Filament Lamps," states in section 4.2, *Ambient Temperature*, "For precise measurement of photometric and electric characteristics of luminaires with HID and incandescent lamps, the ambient temperature should be maintained at 25 °C ±5 °C (77 °F ±9 °F). This temperature shall be measured at a point not more than 1.5 meters (5 feet) from the lamp or luminaire and at the same height as the lamp or luminaire. The temperature-sensing device shall be shielded from direct radiation of the light source." LM-46-04 also includes requirements about air movement. Section 4.3, *Air Movement*, states, "The luminaire (or test lamp during calibration) shall be tested in relatively still air. A maximum airflow of 0.08 meters/second (15 ft./minute) is suggested."

d. IESNA LM-47-01, "IESNA Approved Method for Life Testing of High Intensity Discharge (HID) Lamps," states in section 2.3 *Temperature*, "Ambient temperature should be controlled within the limits set by the lamp manufacturer and ballast manufacturer. When the recommended testing temperature range is exceeded, life testing should be suspended." LM-47-01 also includes information about airflow. Section 2.4, *Airflow*, states, "Airflow does not normally impact the performance of HID lamps. However, special test conditions such as unjacketed lamps operating in open areas may require consideration of this effect."

e. IESNA LM-51-00, "IESNA Approved Method for the Electrical and Photometric Measurements of High Intensity Discharge Lamps," states in section 2.3, *Air Movement*, "No special

precautions against normal room air movements are necessary."

f. IESNA LM-73-04, "IESNA Guide for Photometric Testing of Entertainment Lighting Luminaires Using Incandescent Filament Lamps or High Intensity Discharge Lamps," states in section 2.2, *Ambient Temperatures*, "The ambient temperature of the photometric laboratory shall be maintained at 25 °C ±5 °C (77 °F ±9 °F)." There is no mention of airflow in LM-73-04.

DOE did not receive any negative comments regarding its proposed ambient temperature requirement. Although the ambient temperature requirements differ in IEC 62301 compared to ANSI C82.6 by 2 °C, DOE is adopting the proposed temperature requirements in the NOPR. DOE believes that its ambient temperature requirement is largely consistent with the IEC standard, and furthermore, 25 °C ±5 °C is the standard temperature for lighting measurements for a variety of light sources including HID, fluorescent, and light-emitting diodes.

In summary, DOE found that airflow requirements vary across the technical literature. IEC 62301 sets an airflow of ≤ 0.5 m/s regardless of the technology. Neither ANSI C82.6-2005 nor the normative references listed in ANSI C82.6-2005 define either of the terms "draft free" or "still air." IESNA LM-51-00, published in 2000, specifically states that no precautions for air movement are necessary. ANSI C78.389, published in 2004, requires "draft-free," yet it does not define the term. LM-46-04, published in 2004, uses the term "relatively still air" and provides the quantitative metric of "0.08 meters/second (15 ft./minute)." DOE continues to believe that it is important to specify a maximum airflow requirement as part of the test conditions, as an acknowledgement of industry practices intended to minimize forced convection cooling that could affect measured photometric and electrical data. NEMA agreed that airflow should be minimized when conducting testing under the test procedure. Although DOE found conflicting information regarding airflow in the context of testing HID lamps and luminaires, DOE has decided to adopt the airflow metric from IEC 62301 (*i.e.*, the airflow shall be ≤ 0.5 m/s) in today's final rule. DOE believes not only that this airflow value will achieve its intended purpose, but also that it is consistent with IEC 62301 (the standard which DOE was directed to consider when developing this test procedure) and is in the range of differing airflow values and definitions DOE observed in its review of ANSI standards and IESNA

test methods relevant to this type of equipment.

Section 4.2, *Ballast Conditions*, of ANSI C82.6-2005 requires maintenance of ambient temperature but does not discuss ballast equilibrium. In the NOPR, DOE did not propose to require operation of the ballast until it reached equilibrium. However, NEMA commented that in a proposed revision to sections 4.2 and 4.4 of ANSI C82.6, the ballast would be required to reach equilibrium. (NEMA, No. 21 at p. 1) In response, DOE has considered this issue and concluded that operating the ballast until it reaches equilibrium will produce more reliable results. Therefore, in the final rule, DOE is adopting the language consistent with the following language supplied by NEMA: "The ballast should be operated until it reaches equilibrium." (NEMA, No. 21 at p. 2)

In the NOPR, DOE proposed to adopt the instrumentation requirements prescribed in sections 4.5.1 and 4.5.3 of ANSI C82.6-2005 in order to ensure repeatability and consistency of test measurements. The ANSI requirements for digital voltmeters, ammeters, and wattmeters include a resolution of three and one-half digits and minimum basic instrumentation accuracy of 0.50 percent (*i.e.*, one-half of 1 percent) of the reading from actual with true RMS capability. For analog instruments, the ANSI standard specifies that analog ammeters and voltmeters must have accuracies of ± 0.50 percent up to 800 Hertz (Hz), and that analog wattmeters must have accuracies of ± 0.75 percent up to 1000 Hz for power factors of 50 percent to 100 percent and ± 0.50 percent up to 125 Hz for ballasts with power factors between 0 and 20 percent. In the NOPR, to ensure a full range of coverage, DOE proposed to require all analog wattmeters used on ballasts with power factors less than 50 percent to same accuracy as those for ballasts with power factors less than 20 percent (*i.e.*, ± 0.50 percent up to 125 Hz). 74 FR 33171, 33176 (July 10, 2009).

NEMA agreed in general with the proposed instrumentation and requirements; however, the commenter argued that the DOE test procedure should only permit the use of digital instruments, because digital equipment offers improved repeatability and accuracy of measurement. (NEMA, No. 21 at p. 2) PG&E commented during the public meeting that ANSI allows both digital and analog instrumentation, but finds that digital instruments are the standard industry instrumentation and that analog instruments with low impedance and high accuracy are not common. (PG&E, Public Meeting

Transcript, No. 11, at pp. 19–20) No comments were received specifically addressing the instrument accuracies for any ballasts with power factors between 20 and 50 percent.

DOE agrees that digital equipment offers improved repeatability and accuracy of measurement over analog equipment. However, DOE is concerned about the burden on manufacturers of requiring the use of only digital meters. Furthermore, DOE believes that although the digital meters do provide inherent benefits, analog meters are still able to provide sufficient accuracy and precision when used under the DOE test procedure. Therefore, this final rule does not require use of measurement equipment that is limited to digital meters exclusively. Instead, the test procedure adopted today allows the flexibility of allowing interested parties to test using either a digital or an analog meter, as long as the device meets the precision requirements of this test procedure. Furthermore, in light of the absence of adverse comment, DOE is adopting the proposed instrument accuracies for ballasts with power factors between 20 percent and 50 percent in this final rule.

Finally, section 4.5.1 instructs that only one analog instrument may be connected to the test circuit at one time to reduce impedance effects on the testing. As set forth in ANSI C82.6–2005, all these instrumentation requirements would facilitate repeatable and consistent testing and measurement. NEMA agreed with the proposed test connection requirements. (NEMA, No. 21 at p. 2) Since DOE did not receive any other comments on this issue and the only comment received agreed with the connection procedure proposed in the July 2009 NOPR, DOE is adopting the proposed connection requirements in this final rule.

### c. Lamp Stabilization

A 100-hour seasoning period is commonly used by manufacturers of high-intensity discharge lamp technologies to ensure that the initial, more-rapid depreciation in output caused by impurities has been surpassed.<sup>5</sup> In the NOPR, DOE proposed to adopt the section 4.4 of ANSI C82.6–2005, which requires a 100-hour seasoning period (74 FR 33171, 33177 (July 10, 2009)), and requested comments on whether a preferred alternative lamp seasoning lamp stabilization approach exists within the

industry. *Id.* NEMA commented on lamp and ballast equilibrium and stabilization, but did not provide any comments specifically addressing lamp seasoning. Because DOE did not receive any comments to the contrary and because a 100-hour seasoning period is the industry standard, DOE is adopting this requirement in today's final rule.

In the NOPR, DOE evaluated the requirements of the basic stabilization method prescribed in section 4.4.2 of ANSI C82.6–2005. *Id.* NEMA commented on basic stabilization and recommended that DOE adopt the revised ANSI C82.6 text regarding basic stabilization. (NEMA, No. 21 at p. 1) In order to respond to the comment, DOE compared the text of ANSI C82.6–2005 section 4.4.2 with the text supplied by NEMA of the expected revised ANSI C82.6 section 4.4.2. The text supplied by NEMA states that fast-acting or make-before-break switches are recommended. DOE finds this test procedure clarification helpful, and, therefore, as part of today's final rule, DOE is adopting the revised language suggested by NEMA regarding recommendations of switches to prevent the lamps from extinguishing during switchover.

Operational stability has been defined as the lamp operating in a power equilibrium determined by three consecutive measurements, 5 minutes apart, of the lamp power where the three readings are within 2.5 percent. (NEMA, No. 21 at p. 2) In the NOPR, DOE proposed that the lamp and ballast system be considered stable for testing purposes when the lamp's electrical characteristics vary by no more than 3 percent in three consecutive 10- to 15-minute intervals measured after the minimum 30-minute warm-up period specified in section 4.4.2 of ANSI C82.6–2005. 74 FR 33171, 33177 (July 10, 2009). NEMA suggested language for an alternative stabilization method for electronic ballasts, which provided that the same lamp will be driven by the ballast under test until the ballast reaches operational stability. (NEMA, No. 21 at p. 2) DOE agrees with NEMA's suggestion above for revision of section 4.4.3.2 of ANSI C82.6 because this provides more specificity for determining stability. DOE is adopting NEMA's suggested revision because this provides more specificity for determining stability. Rather than simply assuming that 15 minutes is sufficient to determine stability, the testing agent will take 3 measurements 5 minutes apart (3 times 5 minutes = 15 minutes), and as long as the three readings are within the 2.5-percent tolerance, then the testing agent can

determine the ballast is operationally stable. Thus, DOE is adopting the requirement pertaining to operational stability in order to add more accuracy to the test procedure.

In the NOPR, DOE proposed that electrical measurements should be taken within 2 minutes after the stabilization period. 74 FR 33171, 33177 (July 10, 2009). NEMA commented that the current revised requirements of section 4.4.3.3 of ANSI C82.6 provide that the electrical measurements should be taken within 5 minutes after the stabilization period. (NEMA, No. 21 at p. 2) DOE agrees with NEMA's suggestion for revision of section 4.4.3.3 of ANSI C82.6. DOE believes that given the more technically rigorous definition of stability (as discussed in section III.B.1.c above), the measurements no longer need to be taken within 2 minutes after stabilization. Under the basic stabilization method, the measurements are taken within 5 minutes. DOE has concluded that further consistency would be provided by also requiring measurements to be taken within 5 minutes for the alternate stabilization method. Measurements will be taken within the same amount of time under either stabilization method. Moreover, DOE does not expect accuracy to be affected by changing the time period for the required measurements from 2 minutes to 5 minutes. This change in response to NEMA's comment is expected to maintain test accuracy, while reducing test burden. Therefore, in today's final rule, DOE is requiring measurements to be taken within 5 minutes after stabilization.

### 2. Test Measurements

DOE requires that test measurements of metal halide lamp ballast operation be used in the calculation of ballast efficiency, as discussed in section III.B.3, "Ballast Efficiency Calculation," of this document. This calculated ballast efficiency is an integral part of the metal halide lamp ballast test procedures established under 42 U.S.C. 6293.

In the NOPR, DOE proposed test measurements for metal halide lamp ballasts to require that ballast operation testing be conducted according to the same requirements set forth in section 6.10, "Ballast Power Loss," of ANSI C82.6–2005. 74 FR 33171, 33177 (July 10, 2009). NEMA commented that measurements of ballast power losses should be based on the latest draft of ANSI C82.6 (now being revised by ANSI), but NEMA did not specify what aspects of the draft standard should be incorporated into DOE's test method. (NEMA, No. 21 at p. 3)

<sup>5</sup> IESNA LM-54-99, "Lamp Seasoning," is the lighting measurement (LM) document to which the industry refers for seasoning requirements for lamp and ballast photometric and electrical testing. Available at: <http://www.ies.org/shop/>.

DOE tried to find a current (as of winter 2009) draft of revised ANSI C82.6, but was unable to obtain a copy. Repeatedly, DOE was told by members of NEMA and the ANSI committee revising the document that the 2005 version of ANSI C82.6 is the latest draft. DOE learned that a revised version would not be published until at least March 2010. DOE received a copy of Draft #8 (dated April 15, 2009) in May 2009. DOE compared the text of section 6.10, *Ballast Power Loss*, in ANSI C82.6–2005 to the text in section 6.13, *Ballast Power Loss*, in ANSI C82.6 Draft–April 15, 2009. DOE found a total of 14 words different between the two versions of the text. More specifically, the 2005 version uses the term “potential coil” in two places, as shown below in the 2009 draft text, with the bracketed language indicating the use in the 2005 version. The 2009 draft version also added the following text: “The meters must measure using ranges that minimize these differences.” With that introductory explanation, section 6.13, *Ballast Power Loss*, of ANSI C82.6 Draft–April 15, 2009 reads as follows:

“The power loss should be determined by the wattmeter (power analyzer) difference method, in which the output power is subtracted from the input power. If the instruments are connected as shown in Figure 2, either the voltmeter should be disconnected when the reading of input wattage is taken or a correction should be made to compensate for the power consumed by the voltmeter. It should also be noted that with the connections shown in Figure 2, the wattmeter reading will include the power consumed by the wattmeter itself [potential coil]. This power in the wattmeter [potential coil]; therefore, must be calculated and subtracted to obtain the actual input power. To minimize deviations in power loss calculations, it is recommended that where feasible the same wattmeter and the same potential and current ranges be used to measure both input and lamp watts. Note that in determining ballast losses, it must be kept in mind that when one accurate number is subtracted from a nearly equal accurate number, the percent error of difference may be very great. The deviation in watts loss figures may be as high as  $\pm 10\%$ – $15\%$  when wattmeters with a stated accuracy of  $\pm 0.5\%$  are employed. The meters must measure using ranges that minimize these differences.”

Thus, the ballast power loss section specifies measurements of output power to the lamp and input power to the ballast using a wattmeter, and it specifies the proper instrument connections. The section also provides the necessary guidance and methods for eliminating or compensating for the power consumption of a voltmeter (when connected) and the wattmeter. In summary, the ballast power loss section

of ANSI C82.6–2005 provides a measurement of power using a well-defined, common electrical industry standard test with dedicated equipment.

In general, DOE has decided to adopt the test measurement provisions proposed in the July 2009 NOPR in today’s final rule. Based on the comparison between the published ANSI C82.6–2005 and the draft of the revision dated April 15, 2009, DOE found little substantive change between the ballast power loss sections. If new or more substantive changes occur in a later published revision of ANSI C82.6, DOE will consider revising the test procedure in the future. Other, specific comments on the proposed test measurement provisions are addressed immediately below.

In the NOPR, DOE proposed using a wattmeter to measure ballast power. 74 FR 33171, 33177 (July 10, 2009). In its comments, NEMA indicated a preference for the use of a multi-channel wattmeter in order to minimize measurement uncertainty. (NEMA, No. 21 at p. 3) In response, DOE acknowledges that the use of a multi-channel wattmeter is one way to minimize measurement uncertainty, and notes that today’s test procedure does allow for the use of multi-channel wattmeters. However, there are other ways of reducing uncertainty such as taking sequential measurements using the meter. Therefore, DOE does not find it necessary to require the use of a multi-channel wattmeter in the final rule.

In the NOPR, DOE proposed that the wattmeter used when testing be a “true RMS wattmeter.” 74 FR 33171, 33177 (July 10, 2009). NEMA objected to the use of the term “true RMS wattmeter,” arguing that there is no such thing as a “true RMS wattmeter.” NEMA stated that “[v]oltage and current measuring devices can provide true RMS values, but the power consumed is the time average of the instantaneous voltage and current waveforms, by definition, for any waveform.” As a more technically-accurate alternative, NEMA suggested that DOE use the term “wattmeter” capable of indicating true RMS power in watts” could be used. (NEMA, No. 21 at p. 3) DOE acknowledges that a “true RMS wattmeter” does not exist and cannot require the use of a meter that does not exist. Therefore, DOE has adopted use of the expression “wattmeter capable of indicating true RMS power in watts” in the final rule.

In the NOPR, DOE proposed adopting the test circuit connection requirements of sections 4.5 and 6.10 of ANSI C82.6–2005 in the test procedure. 74 FR 33171, 33181 (July 10, 2009). NEMA expressed

agreement with the proposed connection requirement in the July 2009 NOPR. (NEMA, No. 21 at p. 2) Because DOE received no other comments regarding connection requirements, DOE is adopting the requirements for connections proposed in the July 2009 NOPR in this final rule.

### 3. Ballast Efficiency Calculation

In the NOPR, DOE proposed that ballast efficiency be calculated as the measured output power to the lamp divided by the measured input power to the ballast ( $P_{out}/P_{in}$ ). DOE also proposed that the  $P_{out}$  and  $P_{in}$  terms be determined according to the Ballast Power Loss method described in section III.C.2, “Test Measurements,” of the NOPR, with both output and input power measured in accordance with section 6.10 of ANSI C82.6–2005. 74 FR 33171, 33177 (July 10, 2009). DOE did not receive any comments on the ballast efficiency calculation. It is further noted that this measure of efficiency represents the metric used in the energy conservation standard prescribed by the statute. (42 U.S.C. 6295(hh)(1)) This is a standard method of calculating efficiency. Therefore, for the above reasons; DOE is adopting  $P_{out}/P_{in}$  as the ballast efficiency calculation in today’s final rule.

### C. Test Method for Measuring Standby Power of Metal Halide Lamp Ballasts

#### 1. Overview of Test Method

In relevant part, EPCA directs DOE to establish test procedures to include standby mode, “taking into consideration the most current versions of Standards 62301 and 62087 of the International Electrotechnical Commission.” (42 U.S.C. 6295(gg)(2)(A)) IEC Standard 62087 applies to audio, video, and related equipment but not to lighting equipment. Thus, DOE has determined that IEC Standard 62087 is not suitable to be applied to this rulemaking. Instead, DOE developed today’s test procedure to be consistent with IEC Standard 62301. In addition, to develop a test method that would be familiar to metal halide lamp ballast manufacturers, DOE also referenced language and methodologies presented in ANSI C82.6–2005, “Ballasts for High-Intensity Discharge Lamps—Methods of Measurement.”

Generally, today’s final rule adopts test procedure provisions for measuring standby power that include the following steps: (1) A signal is sent to the ballast instructing it to reduce light output to zero percent; (2) The main input power to the ballast is measured; and (3) The power from the control signal path is measured in one of three

ways, depending on how the signal from the control system is delivered to the ballast. Further detail on DOE's adopted methodology for measuring standby power of metal halide lamp ballasts is presented below. DOE did not receive any adverse comments on the test procedure's standby provisions as a whole, but it did receive comments on this topic pertaining to specific sections of the test procedure. These detailed comments will be addressed in the following sections.

## 2. Test Method and Measurements

In the portion of the metal halide lamp ballast test procedure dealing with standby power measurement, the test procedure requires that a signal be sent to the ballast under test, instructing the ballast to have zero percent light output using the appropriate communication protocol or system for that unit. Next, the input power (in watts) to the ballast is measured in accordance with ANSI C82.6–2005. Finally, the power from the ballast control signal path is measured using a method for an AC, DC, or PLC control signal path, consistent with the type of path that the ballast employs.

The measurement of input power to the ballast from the main electricity supply during standby mode is based on the approach in ANSI C82.6–2005, section 6. This measurement parallels the approach DOE is requiring for measuring the active mode power consumption for input power (watts) to the ballast in accordance with ANSI C82.6–2005. Thus, test measurements of ballast input power are conducted in accordance with the appropriate sections of the industry test standard.

As adopted in today's final rule at 10 CFR 431.324(c), manufacturers must measure the ballast's control signal power. DOE understands there are four possible ways of delivering a control signal to a metal halide lamp ballast: (1) A dedicated AC control signal wire; (2) a dedicated DC control signal wire; (3) a PLC control signal over the main supply input wires; and (4) a wireless control signal. DOE is interested in measuring the power consumed by the lighting control signal and is providing three methods for measuring that power, depending on which type of system is being used. As explained above, DOE did not propose in the NOPR to measure the power supplied to a ballast using a wireless control signal because DOE estimates that the power supplied to a ballast using a wireless signal would be very small (in milliwatts), difficult to measure, and unlikely to appreciably affect ballast power consumption. The three circuit diagrams in the final rule require measurement of the control

signal power using either a wattmeter (for the AC control signal wiring and the PLC control signal) or a voltmeter and ammeter (for the DC control signal). DOE is incorporating three circuit diagrams at 10 CFR 431.324(c) in today's final rule to present clearly the intended methods of measurement for each type of control signal communication protocol.

The test procedure proposed in the July 2009 NOPR characterized metal halide lamp ballasts featuring standby mode as utilizing only one type of control signal connection. However, it is technically feasible for one metal halide lamp ballast to feature more than one type of control signal connection. Therefore, DOE has revised the language proposed in the NOPR for 10 CFR 431.324(c)(3) of the test procedure and is instead adopting the following clarified provision as part of today's final rule: "The power from the control signal path will be measured using all applicable methods described" in subsections (c)(3)(i)–(iii) of the test procedure (*i.e.*, AC control signal, DC control signal, and PLC control signal) so that the procedure is capable of determining the maximum energy consumption of a metal halide lamp ballast in standby mode.

DOE recognizes that measuring the power input into a ballast utilizing a PLC control signal will involve measurement of both the power being used by the ballast and the control signal power. During the public meeting, it was discussed that the PLC control signal would be a series of short bursts. These bursts would be expected to use less than a watt of power. (NEMA, Public Meeting Transcript, No. 11 at p. 36) PG&E commented during the public meeting that it is not the PLC control signal that needs to be measured, but the standby power of the equipment receiving the signal. (PG&E, Public Meeting Transcript, No. 11 at p. 36) However, DOE stated in response to PG&E that DOE wanted to make sure that there would not be a lost opportunity to account for it, to the extent a significant amount of energy is consumed by the control signal. (DOE, Public Meeting Transcript, No. 11 at p. 37)

Therefore, in order to measure each of these powers, the equipment used must be able to measure the appropriate frequencies (*i.e.*, 60 hertz for the power used by the ballast and higher frequency for the control signal power). During the public meeting, DOE reasoned that in order to measure the control signal power and isolate the high-frequency signal from the 60 hertz-signal, one would have to use a high-pass filter.

(DOE, Public Meeting Transcript, No. 11 at p. 43) Therefore, the July 2009 NOPR required that "[t]he wattmeter must have a frequency response that is at least 10 times higher than the PLC being measured to measure the PLC signal correctly. The wattmeter must also be high-pass filtered to filter out power a 60 Hz." 74 FR 33171, 33185 (July 10, 2009). DOE received no comments regarding this filter during the comment period. However, as part of the fluorescent lamp ballast standby test procedure rulemaking, DOE did receive a comment from NEMA regarding PLC signals and proper equipment. In that comment, NEMA stated that equipment used to measure PLC power must be capable of measuring the appropriate frequencies, as the power distributed over the input ballast wiring would also include the PLC power. 74 FR 54445, 54451 (Oct. 22, 2009). DOE's statement during the metal halide lamp ballast public meeting (December 2008) was consistent with the comment NEMA provided on the fluorescent ballast standby test procedure, and DOE believes that the situations regarding PLC signals are analogous for both types of ballasts. Thus, in order to account for PLC signal energy use, DOE has adopted the wattmeter requirements as proposed in the NOPR for PLC measurements in this final rule.

The People's Republic of China ("P.R. China") commented that DOE did not consider issues with electromagnetic compatibility associated with the PLC signal in the July 2009 NOPR. P.R. China is concerned that electromagnetic interference from the PLC signal could significantly affect the measurement of standby power. (P.R. China, No. 20 at p. 3) DOE understands that if the PLC signal were a very high-frequency signal (*e.g.*, with a frequency in the megahertz (MHz) range), then the electromagnetic interference from the signal could affect the standby power measurement significantly (*i.e.*, cause variances in the input power measurement by more than a watt). A similar comment was submitted by P.R. China regarding the fluorescent lamp ballast standby test procedure. DOE determined that PLC signals to fluorescent ballasts are on the order of 20 kilohertz (kHz). 74 FR 54445, 54451–52 (Oct. 22, 2009). DOE notes that the Federal Communications Commission only regulates PLC measurements from 150 kHz to 30 MHz so that conducted emissions in this frequency range do not interfere with nearby radio receivers. (47 CFR 15 subpart B) At this time, DOE does not know of any metal halide lamp ballasts with PLC controls. Because shielding

PLC measurements from electromagnetic interference for ballasts is unnecessary for the reasons explained above, DOE has not modified the test procedure to include shielding in today's final rule. However, in the future, DOE will monitor the situation in the event a manufacturer develops a metal halide lamp ballast utilizing a PLC control signal.

### 3. Combining Measurements and Burden

In the NOPR, DOE proposed to require equipment manufacturers subject to this rulemaking to take the two required measurements (*i.e.*, the main input power and the control signal power in standby mode), but did not tell manufacturers how to combine these values or use them in equations pertaining to energy efficiency. 74 FR 33171, 33178 (July 10, 2009). DOE received no comments regarding these measurements. DOE will study how best to use these measurements of standby mode power consumption in a separate rulemaking to review and possibly amend the energy conservation standards for metal halide lamp ballasts, which DOE is required to complete by January 1, 2012, pursuant to EISA 2007. (42 U.S.C. 6295)(hh)(2)).

DOE further notes that today's final rule is designed to produce results that measure standby power consumption in an accurate and repeatable manner, and should not be unduly burdensome on manufacturers to conduct. These objectives are expected to be met by the final rule, particularly given that it is based upon IEC 62301 and follows testing approaches used in ANSI C82.6–2005. Commenters raised a number of issues which could have bearing on the accuracy and repeatability of the results generated under the metal halide lamp ballast test procedure, but these issues have been fully addressed in today's final rule.

### D. Scope of Applicability of Standby Power Test Procedure

This rulemaking broadly addresses ballasts that operate metal halide lamp fixtures, but as explained below and in the July 2009 NOPR, the scope of applicability of the test procedure's standby provisions is expected to be more limited. 74 FR 33171, 33178 (July 10, 2009). After studying the market of commercially-available metal halide lamp ballasts and the statutory definition of "standby mode," DOE is interpreting this mode as only applying to certain ballasts under certain operating conditions. Standby mode only applies to ballasts that incorporate some kind of lighting control system

interface, because these ballasts appear to be the only ones that satisfy the EPCA definition of "standby mode" (which DOE is codifying into its regulations). Specifically, DOE found that only metal halide lamp ballasts with a lighting-control system interface can be "connected to a main power source" and "facilitate the activation or deactivation of other functions (including active mode) by remote switch (including remote control), internal sensor, or timer." (42 U.S.C. 6295(gg)(1)(A)(iii)) Many of these ballasts are designed with advanced circuitry that adds features, including intelligent operation.<sup>6</sup> As discussed in section III.A above, one example of these ballasts would be a DALI-enabled ballast. DALI-enabled ballasts have internal circuitry that is fundamentally part of the ballast design that remains active and consumes energy, even when the ballast is not operating any lamps. DOE is unaware of any types of ballasts, other than those with a lighting-control system interface that would perform standby functions.

As explained above, not all metal halide lamp ballasts need to be tested for standby mode power, because many ballast designs do not meet the statutory definition for operation in standby mode. In fact, most metal halide lamp ballasts sold today are not capable of operating in standby mode, rendering the standby provisions of the test procedure inapposite in terms of those units. Generally, these excluded ballasts are ones that are not active components of a lighting control system; instead, they are controlled simply by having the active power disconnected through use of a manual switch, occupancy sensor, or other system. For these ballasts, light output is reduced to zero percent by disconnecting the main power. However, the ballast would not be in standby mode, as defined by EPCA, because it is no longer connected to a main power source. Thus, the metal halide lamp ballasts subject to standby mode power measurements are those that incorporate some electronic circuit or auxiliary device enabling the ballast to communicate with and be part of a lighting control system (*e.g.*, stand-alone photosensor and ballast or a centralized system). NEMA accepted the DOE approach to apply the standby mode test procedure to metal halide lamp ballasts that incorporate a circuit to enable the ballast to communicate with lighting

<sup>6</sup> "Intelligent operation" means a device which is able to receive information, evaluate that information, and take appropriate action based upon that information. For example, certain ballasts contain a circuit which, when it receives a signal, then takes action to dim light output to a certain level or to switch off the lamp (or other action).

control systems. (NEMA, No. 21. at. p. 4) In light of the above, DOE is adopting this approach as part of today's final rule.

### E. Effective Date of Standby Mode Test Method

As discussed in section II of this final rule, EPCA requires DOE to consider standby mode and off mode for all energy conservation standard final rules issued after July 1, 2010. (42 U.S.C. 6295(gg)(3)(A)) In addition, EPCA states that not later than January 1, 2012, DOE shall publish a final rule to determine whether the standards established for metal halide lamp fixtures should be amended. (42 U.S.C. 6295(hh)(2)) Because this rulemaking may amend the standards for metal halide lamp fixtures but would be issued after July 1, 2010, DOE must consider standby mode and off mode power consumption in that future energy conservation standards rulemaking.

Including these test procedure provisions in the CFR will provide manufacturers additional time to become familiar with standby mode power consumption of certain metal halide lamp ballasts. As DOE conducts energy conservation standards rulemaking reviewing the energy conservation standards for metal halide lamp ballasts, it will take into consideration standby mode power consumption. During that rulemaking, interested parties will already be familiar with the test procedure for measuring and calculating standby mode power consumption and will be better able to understand any ballast design implications that may affect the efficiency of metal halide lamp ballasts.

As discussed in section II and as provided in the amendments at 10 CFR 431.324(c), manufacturers of metal halide lamp ballasts would not need to perform standby measurements under this test procedure to certify compliance with the energy conservation standards for metal halide lamp fixtures that came into effect on January 1, 2009, because those statutory standards do not account for standby mode power consumption. In terms of codification in the CFR, the effective date of this test procedure on metal halide lamp ballasts is 30 days after the date of publication in the **Federal Register**. However, manufacturers will only be required to use the test procedure's standby mode provisions to demonstrate compliance with any future energy conservation standard on the effective date of a final rule establishing amended standards for metal halide lamp fixtures that addresses standby mode power consumption (at which time, DOE

would remove the limitation in 10 CFR 431.324(c)). However, DOE notes that on or after a date 180 days after the date of publication of this final rule, for any representations made about standby mode energy consumption for these products, the standby provisions of this test procedure must be used to measure standby power. (42 U.S.C. 6293(b)(18) and (c)(2))

#### F. Units To Be Tested

Accurate testing of metal halide lamp ballasts requires a statistically meaningful sample of test units to certify that the true mean efficiency of a basic model meets or exceeds the applicable energy conservation standard. In an effort to meet this testing need and to reduce the testing burden on manufacturers, DOE considered four factors in developing sample size requirements for the approach proposed in its July 2009 NOPR: (1) Providing a highly statistically valid probability that a basic model tested meets applicable energy conservation standards; (2) providing a highly statistically valid probability that a manufacturer preliminarily found to be in noncompliance will actually be in noncompliance; (3) assuring compatibility with other sampling plans DOE has promulgated; and (4) minimizing manufacturers' testing time and costs. 74 FR 33171, 33179 (July 10, 2009).

In the July NOPR, DOE proposed a sampling method similar to the method established for fluorescent ballasts (*see* 56 FR 18677, 18682 (April 24, 1991)). At least four ballasts randomly selected would be tested, and a 99-percent confidence limit would be applied. DOE received few comments regarding the units to be tested; therefore, DOE is adopting the proposed language with minor modifications. Comments on this topic and related modifications are discussed below.

In the NOPR, DOE proposed using coefficients of 0.99 for the lower percent confidence limit and 1.01 for the upper confidence limit. 74 FR 33171, 33179 (July 10, 2009). No comments were received regarding the coefficients. The coefficients are intended to reasonably reflect variations in material and in the manufacturing and testing processes. This statistical process applies an industry standard 99-percent confidence level commonly used for evaluation of large populations and is the confidence level applied to other DOE test procedures for products and equipment subject to energy conservation standards, such as compact fluorescent lamps and external power supplies. Therefore, in today's final rule DOE

adopts the coefficients presented in the NOPR.

DOE received two comments from interested parties on the measurement of units to be tested. First, NEMA stated that it accepts the proposed sampling procedure consistent with the approach DOE adopted for fluorescent lamp ballasts. This sampling procedure includes randomly selected ballast samples, not less than four, to calculate the represented value of energy efficiency and to apply the 99-percent confidence limits as proposed. Additionally, NEMA suggested replacing the term "calculated value of energy efficiency" with use of "represented value of energy efficiency" throughout the test procedure. (NEMA, No. 21 at p. 6) DOE notes that in the NOPR, it had used the phrase "calculated value of energy efficiency" in the preamble section of the NOPR, and the phrase "represented value of energy efficiency" in the regulatory text. DOE also notes that for fluorescent lamp ballasts, the phrase "represented value of energy efficiency" is used throughout; therefore, DOE is adopting this phrase and will use it consistently in today's final rule, as suggested by the commenter.

Second, P.R. China commented that the sampling procedure proposed for metal halide lamp ballasts is based on the current sampling procedure used by DOE for fluorescent lamp ballasts. Because there are some differences between a fluorescent lamp ballast and a metal halide lamp ballast, P.R. China requested that DOE provide further comment on the applicability of the sampling procedure for fluorescent lamp ballasts to metal halide lamp ballasts. (P.R. China, No. 20 at p. 3) In response, DOE acknowledges that the sampling procedure is consistent with the approach DOE has used for fluorescent lamp ballasts. The sample size that DOE is adopting in this final rule is a minimum of four. The number of tests must increase until the results meet this rule's requirements, meaning that if the first four samples tested do not have a represented value of energy efficiency within the mean of the sample divided by the applicable coefficient, the manufacturer must continue testing samples until the represented value of energy efficiency is satisfied or the manufacturer cannot submit the data for compliance and certification. DOE believes that any differences between metal halide lamp ballasts and fluorescent lamp ballasts will be alleviated by the degree of the confidence limit (*i.e.*, 99-percent).

Accordingly, in light of the above considerations and comments, DOE is

adopting the sampling procedure below for testing metal halide lamp ballast energy efficiency. The adopted procedure for metal halide lamp ballasts is consistent with the approach used for fluorescent lamp ballasts and requires randomly selecting and testing a sample of production units (not fewer than four) of a representative basic model. A simple average of the values would be calculated, which would be the actual mean value of the sample. For each representative model, a sample of sufficient size (no less than four) would be selected at random and tested to ensure that:

1. The represented value of energy efficiency is no less than the higher of the mean of the sample or the upper 99-percent confidence limit of the true mean divided by 1.01.
2. The represented value of energy efficiency is no greater than the lower of the mean of the sample or the lower 99-percent confidence limit of the true mean divided by 0.99.

#### G. Submission of Data

Metal halide lamp fixture manufacturers have been required to comply with the statutory standards in EISA 2007 regarding ballast efficiency since January 1, 2009. However, since a final test procedure has not been published until this final rule, manufacturers could not submit data demonstrating compliance. In the NOPR, DOE proposed that the manufacturer, or other entity performing the test on behalf of the manufacturer, would be required to provide certification in a report submitted before a date one year after publication of the test procedure final rule, which would include for each basic model: (1) The equipment type; (2) manufacturer's name; (3) private labeler's name(s) (if applicable); and (4) manufacturer's model number(s). 74 FR 33171, 33180 (July 10, 2009). NEMA accepted the DOE proposal for data submission by certification report. (NEMA, No. 21 at p. 6) Given the absence of any adverse comment, DOE is adopting the submission of data requirements proposed in the NOPR as part of this final rule.

Specifically, in submitting the report, manufacturers certify that the testing was completed in accordance with the applicable test requirements prescribed pursuant to 42 U.S.C. 6293(b) of EPCA, as amended. Any change to a basic model that changes energy consumption constitutes a new basic model. If such a change reduces consumption, the new model would be considered in compliance with the standard without any additional testing. However, if such

a change increases consumption while meeting the standard, then all certification information applicable to testing of the new basic model would be required to be submitted.

#### H. Enforcement Provisions

A Federal energy conservation standard became effective for metal halide lamp ballasts on January 1, 2009; therefore, use of the appropriate application of the testing procedure for this equipment for purposes of compliance with and enforcement of the efficiency requirements is required upon the effective date of this final rule. In the NOPR, DOE proposed applying to metal halide lamp ballasts the same basic requirements for enforcement currently in place for other lighting equipment. 74 FR 33171, 33180 (July 10, 2009). NEMA commented that it recognized and supported the need for inclusion of enforcement provisions for verification of energy efficiency claims. (NEMA, No. 21 at p. 6) As part of today's final rule, DOE is adopting the proposed testing certification as presented in the NOPR.

If DOE receives written information about the performance of metal halide lamp ballasts indicating that one or more basic models may not be in compliance with the energy conservation standard, DOE may conduct independent testing of those basic models. The results of this testing would serve as the basis for any enforcement actions related to the application of these metal halide lamp ballast test procedures.

#### I. Provisions for Compliance, Certification, and Enforcement

The purpose of establishing compliance, certification, and enforcement regulations is to provide reasonable assurance that manufacturers appropriately test and accurately represent the performance characteristics of covered equipment. Accordingly, today's final rule specifies certification, compliance, and enforcement requirements for ballasts that are part of metal halide lamp fixtures. It is noted that DOE plans to address certification, compliance, and enforcement provisions for all consumer products and commercial and industrial equipment covered by EISA 2007 in a separate proceeding, a rulemaking which would not only provide a centralized location for those provisions but which would also promote consistency of such requirements. At that time, DOE will consider moving the certification, compliance, and enforcement provisions being adopted in today's final rule to a different

section in the CFR dedicated to compliance, certification, and enforcement.

#### IV. Procedural Issues and Regulatory Review

##### A. Review Under Executive Order 12866

Today's regulatory action is not a "significant regulatory action" under section 3(f) of Executive Order 12866, "Regulatory Planning and Review." 58 FR 51735 (Oct. 4, 1993). Accordingly, this proposed regulatory action was not subject to review under the Executive Order by the Office of Information and Regulatory Affairs (OIRA) in the Office of Management and Budget (OMB).

##### B. Review Under the Regulatory Flexibility Act

The Regulatory Flexibility Act (5 U.S.C. 601 *et seq.*, as amended by the Small Business Regulatory Enforcement Fairness Act of 1996) requires preparation of an initial regulatory flexibility analysis for any rule that, by law, must be proposed for public comment, unless the agency certifies that the proposed rule, if promulgated, will not have a significant economic impact on a substantial number of small entities. A regulatory flexibility analysis examines the impact of the rule on small entities and considers alternative ways of reducing negative effects. Also, as required by Executive Order 13272, "Proper Consideration of Small Entities in Agency Rulemaking," 67 FR 53461 (August 16, 2002), DOE published procedures and policies on February 19, 2003, to ensure that the potential impact of its rules on small entities are properly considered during the DOE rulemaking process. 68 FR 7990. DOE made its procedures and policies available on the Office of the General Counsel's Web site at <http://www.gc.doe.gov>.

Today's final rule adopts test procedures that are to be used to determine compliance with the energy conservation standard for certain metal halide lamp fixtures. DOE reviewed today's final rule under the provisions of the Regulatory Flexibility Act and the policies and procedures published on February 19, 2003. For the reasons explained in the July 2009 NOPR, DOE certified that the proposed rule would not have a significant economic impact on a substantial number of small entities manufacturing the equipment that are the subject of this rulemaking. 74 FR 33171, 33182 (July 10, 2009).

The test procedure incorporates by reference provisions from ANSI Standard C82.6–2005 for the measurement of ballast efficiency. ANSI Standard C82.6–2005 is the current and

active industry testing standard for metal halide lamp ballasts. In referencing this industry test method, DOE anticipates that there would be no incremental increase in testing cost or burden for covered equipment. Manufacturers are familiar with the application of ANSI Standard C82.6–2005 and should have the equipment necessary to conduct the performance measurements. Furthermore, DOE understands that manufacturers of covered equipment are using this industry test method when they make any representation of their product's efficiency in the public domain.

Today's final rule also establishes a methodology for the measurement of standby mode power consumption for certain metal halide lamp fixtures. DOE based its method on techniques and approaches in ANSI Standard C82.6–2005 and IEC Standard 62301. DOE uses the same test equipment, accuracy requirements, and test conditions from ANSI Standard C82.6–2005. Although DOE is unaware of any metal halide lamp ballasts commercially available today that are capable of operating in standby mode, ballasts incorporating features that may encounter standby mode may enter the market as they have for fluorescent lamp ballasts. Due to the fact that DOE's method is based on the industry standards and does not exceed the equipment and accuracy recommendations in NEMA's comments (see III.A, in the discussion of "ballast efficiency"), DOE does not believe the standby mode test procedure will add significant costs. Of the two measurements required in the standby mode test procedure, the  $P_{in}$  measurement is common to both the active mode and the standby mode test procedure. Measurement of the control signal is a minimal additional test, but one that technicians can conduct with measurement equipment readily available.

Accordingly, DOE has not prepared a regulatory flexibility analysis for this rulemaking. DOE's certification and supporting statement of factual basis was provided to the Chief Counsel for Advocacy of the Small Business Administration for review under 5 U.S.C. 605(b). DOE did not receive any comments regarding the impact on small business manufacturers of metal halide lamp fixtures. Thus, DOE reaffirms and certifies that this rule will have no significant economic impact on a substantial number of small entities.

##### C. Review Under the Paperwork Reduction Act of 1995

Today's final rule would require each manufacturer of metal halide lamp



fixtures (*i.e.*, fixtures that incorporate metal halide lamp ballasts), or entity performing tests on behalf of the manufacturer, to maintain records about how they determined the energy efficiency measurement—and on the date of any amended standards incorporating standby power usage, standby power mode energy consumption measurement—of their equipment (*see* regulatory language at 10 CFR Part 431 subpart S). The rule also requires each manufacturer to make a one-time submission to DOE, stating that it is complying with the applicable energy conservation standards and test procedures, in addition to certification reports that set forth the energy performance of each basic model that it manufactures. The certification reports to DOE are submitted one time for each basic model, either when the requirements go into effect or when the manufacturer begins distribution of a new basic model. The collection of information is necessary for implementing and monitoring compliance with the efficiency standards and testing requirements for metal halide lamp fixtures, as mandated by EPCA. Manufacturers would become subject to these reporting and certification requirements once both a final rule for the metal halide lamp ballast test procedure and a standard for the metal halide lamp fixture energy conservation standard are effective. The metal halide lamp fixture energy conservation standard referenced earlier is already effective (EISA 2007). Upon the effective date of this final rule, manufacturers would become subject to these reporting and certification requirements.

DOE estimates the total annual reporting and recordkeeping burden imposed on manufacturers of metal halide lamp fixtures by today's proposed rule would be 23,680 hours per year. DOE estimates that the number of covered manufacturing firms would be approximately 148, and the total annual recordkeeping burden from compliance with the proposed rule would be 160 hours per company. Thus, 148 firms  $\times$  160 hours per firm = 23,680 hours per year. In developing this burden estimate, DOE considered that each manufacturer is required to comply with the energy conservation standards for metal halide lamp fixtures set by the statute for ballasts manufactured on or after the effective date of the relevant statutory provisions (*i.e.*, January 1, 2009). DOE understands that manufacturers already maintain the types of records the final rule would require them to keep, and believes the

collection of information required by this final rule is the least burdensome method of meeting the statutory requirements and achieving the program objectives of the compliance certification program for these products and equipment.

An agency may not conduct or sponsor, and a person is not required to respond to, a collection of information unless it displays a currently valid OMB control number. DOE will submit this information collection request to OMB for review and approval. Notice of OMB approval and the control number will be published in the **Federal Register**.

#### *D. Review Under the National Environmental Policy Act*

DOE is establishing a final rule for metal halide lamp ballast test procedure that it expects will not only be used to test under current standards, but which would also be used to develop and implement future energy conservation standards for metal halide lamp ballasts. DOE has determined that this final rule falls into a class of actions that are categorically excluded from review under the National Environmental Policy Act of 1969 (Pub. L. 91–190, codified at 42 U.S.C. 4321 *et seq.*), and DOE's implementing regulations at 10 CFR part 1021. Specifically, this final rule would adopt existing industry ballast test procedures, so it would not affect the amount, quality, or distribution of energy usage, and, therefore would not result in any significant effect on the human environment. Thus, this rulemaking is covered by Categorical Exclusion A6 under 10 CFR part 1021, subpart D.<sup>7</sup> Accordingly, neither an environmental assessment nor an environmental impact statement is required.

#### *E. Review Under Executive Order 13132*

Executive Order 13132, "Federalism," 64 FR 43255 (August 10, 1999), imposes certain requirements on agencies formulating and implementing policies or regulations that preempt State law or that have Federalism implications. The Executive Order requires agencies to examine the constitutional and statutory authority supporting any action that would limit the policymaking discretion of the states and to assess carefully the necessity for such actions. The

<sup>7</sup> Categorical Exclusion A6 provides, "Rulemakings that are strictly procedural, such as rulemaking (under 48 CFR part 9) establishing procedures for technical and pricing proposals and establishing contract clauses and contracting practices for the purchase of goods and services, and rulemaking (under 10 CFR part 600) establishing application and review procedures for, and administration, audit, and closeout of, grants and cooperative agreements."

Executive Order also requires agencies to have an accountable process to ensure meaningful and timely input by State and local officials in developing regulatory policies that have Federalism implications. On March 14, 2000, DOE published a statement of policy describing the intergovernmental consultation process that it will follow in developing such regulations. 65 FR 13735. DOE examined this final rule and determined that it would not have a substantial direct effect on the states, on the relationship between the national government and the states, or on the distribution of power and responsibilities among the various levels of government. Accordingly, Executive Order 13132 requires no further action.

#### *F. Review Under Executive Order 12988*

With respect to the review of existing regulations and the promulgation of new regulations, section 3(a) of Executive Order 12988, "Civil Justice Reform," 61 FR 4729 (Feb. 7, 1996), imposes on Federal agencies the duty to: (1) Eliminate drafting errors and ambiguity; (2) write regulations to minimize litigation; (3) provide a clear legal standard for affected conduct rather than a general standard; and (4) promote simplification and burden reduction. Section 3(b) of Executive Order 12988 specifically requires that Executive agencies make every reasonable effort to ensure that the regulation specifies the following: (1) The preemptive effect, if any; (2) any effect on existing Federal law or regulation; (3) a clear legal standard for affected conduct while promoting simplification and burden reduction; (4) the retroactive effect, if any; (5) definitions of key terms; and (6) other important issues affecting clarity and general draftsmanship under any guidelines issued by the Attorney General. Section 3(c) of Executive Order 12988 requires Executive agencies to review regulations in light of applicable standards in sections 3(a) and 3(b) to determine whether they are met or whether it is unreasonable to meet one or more of them. DOE completed the required review and determined that, to the extent permitted by law, this final rule meets the relevant standards of Executive Order 12988.

#### *G. Review Under the Unfunded Mandates Reform Act of 1995*

Title II of the Unfunded Mandates Reform Act of 1995 (UMRA) (Pub. L. 104–4, codified at 2 U.S.C. 1501 *et seq.*) requires each Federal agency to assess the effects of Federal regulatory actions on State, local, and Tribal governments

and the private sector. For regulatory actions likely to result in a rule that may cause expenditures by State, local, and Tribal governments, in the aggregate, or by the private sector of \$100 million or more in any 1 year (adjusted annually for inflation), section 202 of UMRA requires a Federal agency to publish a written statement that estimates the resulting costs, benefits, and other effects on the national economy. (2 U.S.C. 1532(a) and (b)) UMRA requires a Federal agency to develop an effective process to permit timely input by elected officers of State, local, and Tribal governments on a proposed "significant intergovernmental mandate." UMRA also requires an agency plan for giving notice and opportunity for timely input to small governments that may be potentially affected before establishing any requirement that might significantly or uniquely affect them. On March 18, 1997, DOE published a statement of policy on its process for intergovernmental consultation under UMRA. 62 FR 12820. (This policy is also available at <http://www.gc.doe.gov>). Today's final rule contains neither an intergovernmental mandate nor a mandate that may result in the expenditure of \$100 million or more in any year, so these requirements do not apply.

#### H. Review Under the Treasury and General Government Appropriations Act, 1999

Section 654 of the Treasury and General Government Appropriations Act, 1999 (Pub. L. 105-277) requires Federal agencies to issue a Family Policymaking Assessment for any rule that may affect family well-being. Today's final rule to amend DOE test procedures would not have any negative consequence on the autonomy or integrity of the family as an institution. Accordingly, DOE has concluded that it is not necessary to prepare a Family Policymaking Assessment.

#### I. Review Under Executive Order 12630

Pursuant to Executive Order 12630, "Governmental Actions and Interference with Constitutionally Protected Property Rights," 53 FR 8859 (March 15, 1988), DOE determined that this final rule would not result in any takings that might require compensation under the Fifth Amendment to the U.S. Constitution.

#### J. Review Under the Treasury and General Government Appropriations Act, 2001

Section 515 of the Treasury and General Government Appropriations

Act, 2001 (Pub. L. 106-554, codified at 44 U.S.C. 3516 note) provides for agencies to review most disseminations of information to the public under information quality guidelines established by each agency pursuant to general OMB guidelines. OMB's guidelines were published at 67 FR 8452 (Feb. 22, 2002), and DOE's guidelines were published at 67 FR 62446 (Oct. 7, 2002). DOE has reviewed today's final rule under the OMB and DOE guidelines and concluded that it is consistent with applicable policies in those guidelines.

#### K. Review Under Executive Order 13211

Executive Order 13211, "Actions Concerning Regulations That Significantly Affect Energy Supply, Distribution, or Use," 66 FR 28355 (May 22, 2001), requires Federal agencies to prepare and submit to OMB a Statement of Energy Effects for any proposed significant energy action. A "significant energy action" is defined as any action by an agency that promulgated a final rule or is expected to lead to promulgation of a final rule, and that: (1) Is a significant regulatory action under Executive Order 12866, or any successor order; and (2) is likely to have a significant adverse effect on the supply, distribution, or use of energy; or (3) is designated by the Administrator of OIRA as a significant energy action. For any proposed significant energy action, the agency must give a detailed statement of any adverse effects on energy supply, distribution, or use if the proposal is implemented, and of reasonable alternatives to the action and their expected benefits on energy supply, distribution, and use. Today's final rule is not a significant regulatory action under Executive Order 12866. Moreover, it would not have a significant adverse effect on the supply, distribution, or use of energy and has not been designated a significant energy action by the Administrator of OIRA. Therefore, DOE determined that this rule is not a significant energy action. Accordingly, DOE has not prepared a Statement of Energy Effects for this rulemaking.

#### L. Review Under Section 32 of the Federal Energy Administration Act of 1974

Under section 301 of the Department of Energy Organization Act (Pub. L. 95-91; 42 U.S.C. 7101, *et seq.*), DOE must comply with section 32 of the Federal Energy Administration Act of 1974 (Pub. L. 93-275), as amended by the Federal Energy Administration Authorization Act of 1977 (Pub. L. 95-70). (15 U.S.C. 788) Section 32 provides

that, where a proposed rule authorizes or requires use of commercial standards, the NOPR must inform the public of the use and background of such standards. In addition, section 32(c) requires DOE to consult with the Attorney General and the Federal Trade Commission (FTC) about the effect of the commercial or industry standards on competition.

Today's final rule incorporates testing methods contained in the following commercial standards: ANSI C82.6-2005, "American National Standard for Lamp Ballasts—Ballasts for High-Intensity Discharge Lamps—Methods of Measurement, 2005." DOE has evaluated these revised standards and is unable to conclude whether they fully comply with the requirements of section 32(b) of the Federal Energy Administration Act (*i.e.*, that they were developed in a manner that fully provides for public participation, comment, and review). DOE has consulted with the Attorney General and the Chairman of the FTC concerning the affect on competition of requiring manufacturers to use the test methods contained in these standards, and neither recommended against incorporation of these standards.

#### M. Congressional Notification

As required by 5 U.S.C. 801, DOE will report to Congress on the promulgation of today's rule before its effective date. The report will state that it has been determined that the rule is not a "major rule" as defined by 5 U.S.C. 801(2).

#### V. Approval of the Office of the Secretary

The Secretary of Energy has approved publication of this final rule.

#### List of Subjects in 10 CFR Part 431

Administrative practice and procedure, Confidential business information, Energy conservation, Incorporation by reference, Reporting and recordkeeping requirements.

Issued in Washington, DC, on February 19, 2010.

#### Cathy Zoi,

*Assistant Secretary, Energy Efficiency and Renewable Energy.*

■ For the reasons stated in the preamble, DOE amends part 431 of chapter II of title 10, of the Code of Federal Regulations, to read as set forth below.

#### PART 431—ENERGY EFFICIENCY PROGRAM FOR CERTAIN COMMERCIAL AND INDUSTRIAL EQUIPMENT

■ 1. The authority citation for part 431 continues to read as follows:

**Authority:** 42 U.S.C. 6291-6317.

■ 2. Section 431.321 is revised to read as follows:

**Subpart S—Metal Halide Lamp Ballasts and Fixtures**

**§ 431.321 Purpose and scope.**

This subpart contains energy conservation requirements for metal halide lamp ballasts and fixtures, pursuant to Part A of Title III of the Energy Policy and Conservation Act, as amended, 42 U.S.C. 6291–6309.

■ 3. Section 431.322 is amended by:

- a. Removing from paragraph 5 of the definition of “Ballast Efficiency” “2 kHz,” and adding “2.4 kHz” in its place, and
- b. Adding, in alphabetical order, definitions for “AC control signal,” “Active mode,” “Ballast,” “Basic model,” “DC control signal,” “Electronic ballast,” “Off mode,” “PLC control signal,” “Standby mode,” and “Wireless control signal” to read as follows:

**§ 431.322 Definitions concerning metal halide lamp ballasts and fixtures.**

*AC control signal* means an alternating current (AC) signal that is supplied to the ballast using additional wiring for the purpose of controlling the ballast and putting the ballast in standby mode.

*Active mode* means the condition in which an energy-using product:

- (1) Is connected to a main power source;
- (2) Has been activated; and
- (3) Provides one or more main functions.

*Ballast* means a device used with an electric discharge lamp to obtain necessary circuit conditions (voltage, current, and waveform) for starting and operating.

\* \* \* \* \*

*Basic model* means, with respect to metal halide lamp ballasts, all units of a given type of metal halide lamp ballast (or class thereof) that:

- (1) Are rated to operate a given lamp type and wattage;
- (2) Have essentially identical electrical characteristics; and
- (3) Have no differing electrical, physical, or functional characteristics that affect energy consumption.

*DC control signal* means a direct current (DC) signal that is supplied to the ballast using additional wiring for the purpose of controlling the ballast and putting the ballast in standby mode.

*Electronic ballast* means a device that uses semiconductors as the primary means to control lamp starting and operation.

\* \* \* \* \*

*Off mode* means the condition in which an energy-using product:

- (1) Is connected to a main power source; and
- (2) Is not providing any standby or active mode function.

*PLC control signal* means a power line carrier (PLC) signal that is supplied to the ballast using the input ballast wiring for the purpose of controlling the ballast and putting the ballast in standby mode.

\* \* \* \* \*

*Standby mode* means the condition in which an energy-using product:

- (1) Is connected to a main power source; and
- (2) Offers one or more of the following user-oriented or protective functions:
  - (i) To facilitate the activation or deactivation of other functions (including active mode) by remote switch (including remote control), internal sensor, or timer;
  - (ii) Continuous functions, including information or status displays (including clocks) or sensor-based functions.

*Wireless control signal* means a wireless signal that is radiated to and received by the ballast for the purpose of controlling the ballast and putting the ballast in standby mode.

**§ 431.323 [Amended]**

■ 4. Section 431.323 is amended by adding to the end of paragraph (b)(2) “and § 431.324”.

■ 5. Section 431.324 is amended by revising the section heading, revising paragraph (b), and adding paragraph (c) to read as follows:

**§ 431.324 Uniform test method for the measurement of energy efficiency and standby mode energy consumption of metal halide lamp ballasts.**

\* \* \* \* \*

(b) *Testing and Calculations Active Mode.* (1)(i) *Test Conditions.* The power supply, ballast test conditions, lamp position, lamp stabilization, and test instrumentation shall all conform to the requirements specified in section 4.0, “General Conditions for Electrical Performance Tests,” of ANSI C82.6 (incorporated by reference; see § 431.323). Ambient temperatures for the testing period shall be maintained at 25 °C ± 5 °C. Airflow in the room for the testing period shall be ≤0.5 meters/second. The ballast shall be operated until equilibrium. Lamps used in the test shall conform to the general requirements in section 4.4.1 of ANSI C82.6 and be seasoned for a minimum of 100 hour prior to use in ballast tests. Basic lamp stabilization shall conform to the general requirements in section 4.4.2 of ANSI C82.6, and stabilization shall be reached when the lamp’s electrical characteristics vary by no

more than 3-percent in three consecutive 10- to 15-minute intervals measured after the minimum burning time of 30 minutes. After the stabilization process has begun, the lamp shall not be moved or repositioned until after the testing is complete. In order to avoid heating up the test ballast during lamp stabilization, which could cause resistance changes and result in unrepeatable data, it is necessary to warm up the lamp on a standby ballast. This standby ballast should be a commercial ballast of a type similar to the test ballast in order to be able to switch a stabilized lamp to the test ballast without extinguishing the lamp. Fast-acting or make-before-break switches are recommended to prevent the lamps from extinguishing during switchover.

(ii) *Alternative Stabilization Method.*

In cases where switching without extinguishing the lamp is impossible or for low-frequency electronic ballasts, the following alternative stabilization method shall be used. The lamp characteristics are determined using a reference ballast and recorded for future comparison. The same lamp is to be driven by the ballast under test until the ballast reaches operational stability. Operational stability is defined by three consecutive measurements, 5 minutes apart, of the lamp power where the three readings are within 2.5 percent. The electrical measurements are to be taken within 5 minutes after conclusion of the stabilization period.

(2) *Test Measurement.* The ballast input power and lamp output power during operating conditions shall be measured in accordance with the methods specified in section 6.0, “Ballast Measurements (Multiple-Supply Type Ballasts)” of the ANSI C82.6 (incorporated by reference; see § 431.323).

(3) *Efficiency Calculation.* The measured lamp output power shall be divided by the ballast input power to determine the percent efficiency of the ballast under test.

(c) *Testing and Calculations-Standby Mode.* The measurement of standby mode need not be performed to determine compliance with energy conservation standards for metal halide lamp fixtures at this time. The above statement will be removed as part of the rulemaking to amend the energy conservation standards for metal halide lamp fixtures to account for standby mode energy consumption, and the following shall apply on the compliance date for such requirements. However, all representations related to standby mode energy consumption of these products made after September 7, 2010, must be

based upon results generated under this test procedure.

(1) *Test Conditions.* The power supply, ballast test conditions, and test instrumentation shall all conform to the requirements specified in section 4.0, "General Conditions for Electrical Performance Tests," of the ANSI C82.6 (incorporated by reference; see § 431.323) Ambient temperatures for the testing period shall be maintained at  $25^{\circ}\text{C} \pm 5^{\circ}\text{C}$ . Send a signal to the ballast

instructing it to have zero light output using the appropriate ballast communication protocol or system for the ballast being tested.

(2) *Measurement of Main Input Power.* Measure the input power (watts) to the ballast in accordance with the methods specified in section 6.0, "Ballast Measurements (Multiple-Supply Type Ballasts)" of the ANSI C82.6 (incorporated by reference; see § 431.323).

(3) *Measurement of Control Signal Power.* The power from the control signal path is measured using all applicable methods described below:

(i) *DC Control Signal.* Measure the DC control signal voltage, using a voltmeter (V), and current, using an ammeter (A) connected to the ballast in accordance with the circuit shown in Figure 1. The DC control signal power is calculated by multiplying the DC control signal voltage by the DC control signal current.

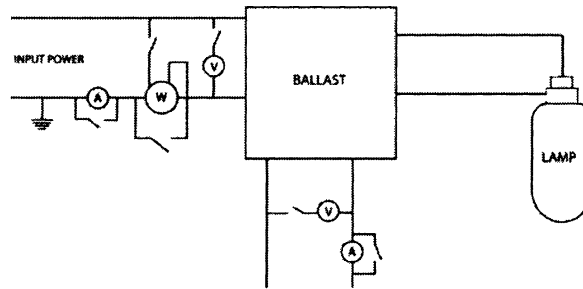
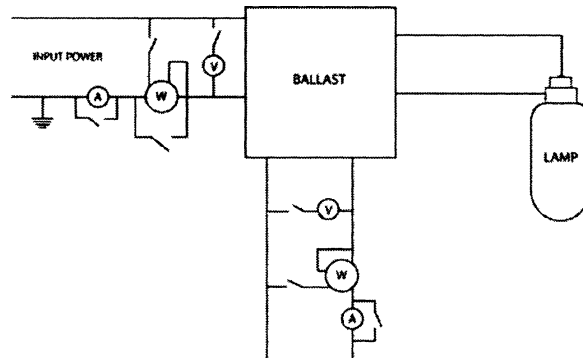

**Figure 1. Circuit for Measuring DC Control Signal Power in Standby Mode**

(ii) *AC Control Signal.* Measure the AC control signal power (watts), using

a wattmeter capable of indicating true RMS power in watts (W), connected to

the ballast in accordance with the circuit shown in Figure 2.

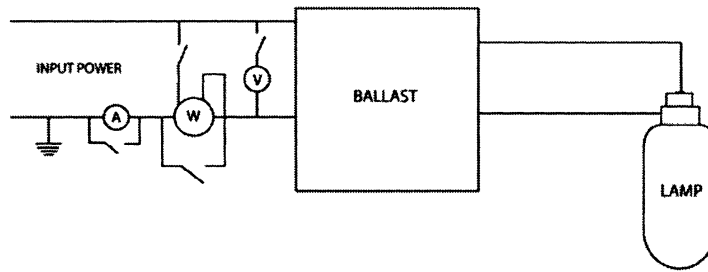

**Figure 2. Circuit for Measuring AC Control Signal Power in Standby Mode**

(iii) *Power Line Carrier (PLC) Control Signal.* Measure the PLC control signal power (watts), using a wattmeter capable of indicating true RMS power in watts (W) connected to the ballast in

accordance with the circuit shown in Figure 3. The wattmeter must have a frequency response that is at least 10 times higher than the PLC being measured to measure the PLC signal

correctly. The wattmeter must also be high-pass filtered to filter out power at 60 Hz.



**Figure 3. Circuit for Measuring PLC Control Signal Power in Standby Mode**

■ 6. Section 431.325 is added to subpart S to read as follows:

**§ 431.325 Units to be tested.**

For each basic model of metal halide lamp ballast selected for testing, a sample of sufficient size, no less than four, shall be selected at random and tested to ensure that:

(a) Any represented value of estimated energy efficiency calculated as the measured output power to the lamp divided by the measured input power to the ballast ( $P_{out}/P_{in}$ ), of a basic model is no less than the higher of:

(1) The mean of the sample, or  
 (2) The upper 99-percent confidence limit of the true mean divided by 1.01.  
 (b) Any represented value of the energy efficiency of a basic model is no greater than the lower of:

(1) The mean of the sample, or  
 (2) The lower 99-percent confidence limit of the true mean divided by 0.99.

■ 7. Sections 431.327, 431.328, 431.329 and Appendices A, B, and C are added to Subpart S to read as follows:

**§ 431.327 Submission of data.**

(a) *Certification.* (1) Except as provided in paragraph (a)(2) of this section, each manufacturer or private labeler, before distributing in commerce any basic model of equipment covered by this subpart and subject to an energy conservation standard set forth in this part, shall certify by means of a compliance statement and a certification report that each basic model meets the applicable energy conservation standard.

(2) Each manufacturer or private labeler of a basic model of metal halide lamp ballast shall file a compliance statement and its first certification report with DOE on or before March 9, 2011.

(3) *Amendment of information.* If information in a compliance statement or certification report previously submitted to the Department under this section is found to be incorrect, each manufacturer or private labeler (or an authorized representative) must submit the corrected information to the

Department at the address and in the manner described in this section.

(4) *Third-party representatives.* Each manufacturer or private labeler shall notify the Department when designating a third-party representative and shall notify the Department of any changes of third-party representatives which is to be sent to the Department at the address and in the manner described in this section.

(5) *Compliance statement.* Each manufacturer or private labeler need submit its compliance statement once. Such statement shall include all required information specified in the format set forth in Appendix A of this subpart and shall certify, with respect to each basic model currently produced by the manufacturer and all new basic models it introduces in the future, that:

(i) Each basic model complies and will comply with the applicable energy conservation standard;

(ii) All representations as to efficiency in the manufacturer's certification report(s) are and will be based on testing conducted in accordance with the applicable test requirements prescribed in this subpart;

(iii) All information reported in the certification report(s) is and will be true, accurate, and complete; and

(iv) The manufacturer or private labeler is aware of the penalties associated with violations of the Act, the regulations thereunder, and 18 U.S.C. 1001, which prohibits knowingly making false statements to the Federal Government.

(6) *Certification report.* Each manufacturer must submit to DOE a certification report for each of its metal halide lamp ballast basic models. The certification report (for which a suggested format is set forth in Appendix B of this subpart) shall include for each basic model the product type, product class, manufacturer's name, private labeler's name(s) (if applicable), the manufacturer's model number(s), and the ballast efficiency in percent. A single certification report may be used

to report required information for multiple basic models.

(7) Copies of reports to the Federal Trade Commission that include the information specified in paragraph (a)(6) of this section could serve in lieu of the certification report.

(b) *Model modifications.* Any change to a basic model that affects energy consumption constitutes the addition of a new basic model. If such a change reduces energy consumption, the new model shall be considered in compliance with the standard without any additional testing. If, however, such a change increases energy consumption while meeting the standard, then the manufacturer must submit all information required by paragraph (a)(6) of this section for the new basic model.

(c) *Discontinued models.* A manufacturer shall report to the Department a basic model whose production has ceased and is no longer being distributed. For each basic model, the report shall include: equipment type, equipment class, the manufacturer's name, the private labeler's name(s) (if applicable), and the manufacturer's model number. If the reporting of discontinued models coincides with the submittal of a certification report, such information can be included in the certification report.

(d) *Third-party representation.* A manufacturer or private labeler may elect to use a third party (such as a trade association or other authorized representative) to submit the certification report to DOE. Such certification reports shall include all the information specified in paragraph (a)(6) of this section. Third parties submitting certification reports shall include the names of the manufacturers or private labelers who authorized the submittal of the certification reports to DOE on their behalf. The third-party representative also may submit model modification information, as specified in paragraph (b) of this section, and discontinued model information, as specified in paragraph (c) of this section, on behalf

of an authorizing manufacturer or private labeler.

(e) *Submission instructions.* All reports and notices required by this section shall be sent by certified mail to: U.S. Department of Energy, Building Technologies Program, Mailstop EE-2J, 1000 Independence Avenue, SW., Washington, DC 20585-0121, or by e-mail to the Department at: *certification.report@ee.doe.gov*. If submitting by e-mail, the compliance statement must be provided in PDF format (which shows the original signature).

#### § 431.328 Sampling.

For purposes of a certification of compliance, the determination that a basic model complies with the applicable energy conservation standard shall be based upon the testing and sampling procedures, and other applicable rating procedures, set forth in this part. For purposes of a certification of compliance, the determination that a basic model complies with the applicable design standard shall be based on the incorporation of specific design requirements specified in this part.

#### § 431.329 Enforcement.

*Process for Metal Halide Lamp Ballasts.* This section sets forth procedures DOE will follow in pursuing alleged noncompliance with an applicable energy conservation standard.

(a) *Performance standards.* (1) *Test notice.* Upon receiving information in writing concerning the energy performance of a particular covered equipment sold by a particular manufacturer or private labeler which indicates that the covered equipment may not be in compliance with the applicable energy standard, the Secretary may conduct a review of the test records. The Secretary may then conduct enforcement testing of that equipment under the DOE test procedure, a process that is initiated by means of a test notice addressed to the manufacturer or private labeler in accordance with the requirements outlined below.

(i) The test notice procedure will only be followed after the Secretary or his/her designated representative has examined the underlying test data provided by the manufacturer, and after the manufacturer has been offered the opportunity to meet with the Department to verify compliance with the applicable energy conservation standard and/or water conservation standard. A representative designated by the Secretary must be permitted to

observe any re-verification procedures undertaken according to this subpart, and to inspect the results of such re-verification.

(ii) The test notice will be signed by the Secretary or his/her designee and will be mailed or delivered by the Department to the plant manager or other responsible official designated by the manufacturer.

(iii) The test notice will specify the basic model to be selected for testing, the number of units to be tested, the method for selecting these units, the date and time at which testing is to begin, the date when testing is scheduled to be completed, and the facility at which testing will be conducted. The test notice may also provide for situations in which the selected basic model is unavailable for testing, and it may include alternative basic models.

(iv) The Secretary may require in the test notice that the manufacturer of covered equipment shall ship at its expense a reasonable number of units of each basic model specified in the test notice to a testing laboratory designated by the Secretary. The number of units of a basic model specified in a test notice shall not exceed 20.

(v) Within five working days of the time the units are selected, the manufacturer must ship the specified test units of a basic model to the designated testing laboratory.

(2) *Testing Laboratory.* Whenever the Department conducts enforcement testing at a designated laboratory in accordance with a test notice under this section, the resulting test data shall constitute official test data for that basic model. The Department will use such test data to make a determination of compliance or noncompliance.

(3) *Sampling.* The Secretary will base the determination of whether a manufacturer's basic model complies with the applicable energy conservation standard on testing conducted in accordance with the applicable test procedures specified in this part, and with the following statistical sampling procedures for metal halide lamp ballasts, with the methods described in 10 CFR Part 431, Subpart S, Appendix C (Sampling Plan for Enforcement Testing).

(4) *Test unit selection.* For metal halide lamp ballasts, the following applies:

(i) The Department shall select a batch, a batch sample, and test units from the batch sample in accordance with the following provisions of this paragraph and the conditions specified in the test notice.

(ii) The batch may be subdivided by the Department using criteria specified in the test notice.

(iii) The Department will then randomly select a batch sample of up to 20 units from one or more subdivided groups within the batch. The manufacturer shall keep on hand all units in the batch sample until the basic model is determined to be in compliance or non-compliance.

(iv) The Department will randomly select individual test units comprising the test sample from the batch sample.

(v) All random selections shall be achieved by sequentially numbering all the units in a batch sample and then using a table of random numbers to select the units to be tested.

(5) *Test unit preparation.* (i) Before and during the testing, a test unit selected in accordance with paragraph (a)(4) of this section shall not be prepared, modified, or adjusted in any manner unless such preparation, modification, or adjustment is allowed by the applicable DOE test procedure. DOE will test each unit in accordance with the applicable test procedures.

(ii) No one may perform any quality control, testing, or assembly procedures on a test unit, or any parts and subassemblies thereof, that is not performed during the production and assembly of all other units included in the basic model.

(iii) A test unit shall be considered defective if it is inoperative. A test unit is also defective if it is found to be in noncompliance due to a manufacturing defect or due to failure of the unit to operate according to the manufacturer's design and operating instructions, and the manufacturer demonstrates by statistically valid means that, with respect to such defect or failure, the unit is not representative of the population of production units from which it is obtained. Defective units, including those damaged due to shipping or handling, must be reported immediately to DOE. The Department may authorize testing of an additional unit on a case-by-case basis.

(6) *Testing at manufacturer's option.*

(i) If the Department determines a basic model to be in noncompliance with the applicable energy performance standard at the conclusion of its initial enforcement sampling plan testing, the manufacturer may request that the Department conduct additional testing of the basic model. Additional testing under this paragraph must be in accordance with the applicable test procedure, and for metal halide lamp ballasts, the applicable provisions in Appendix C to Subpart S to Part 431.

(ii) All units tested under this paragraph shall be selected and tested in accordance with paragraphs (a)(1)(v) and (a)(2) through (5) of this section.

(iii) The manufacturer shall bear the cost of all testing conducted under this paragraph.

(iv) The Department will advise the manufacturer of the method for selecting the additional units for testing under the sampling plan, the date and time at which testing is scheduled to begin, the date by which testing is scheduled to be completed, and the facility at which the testing will occur.

(v) The manufacturer shall cease distribution of the basic model tested under the provisions of this paragraph from the time the manufacturer elects to exercise the option provided in this paragraph until the basic model is determined to be in compliance. The Department may seek civil penalties for all units distributed during such period.

(vi) If the additional testing results in a determination of compliance, the Department will issue a notice of allowance to resume distribution.

(b) *Cessation of distribution of a basic model of commercial equipment other than electric motors.* (1) In the event the Department determines, in accordance with enforcement provisions set forth in this subpart, that a model of covered equipment is noncompliant, or if a manufacturer or private labeler determines one of its models to be in noncompliance, the manufacturer or private labeler shall:

(i) Immediately cease distribution in commerce of all units of the basic model in question;

(ii) Give immediate written notification of the determination of noncompliance to all persons to whom the manufacturer has distributed units of the basic model manufactured since the date of the last determination of compliance; and

(iii) If requested by the Secretary, provide DOE, within 30 days of the request, records, reports and other documentation pertaining to the acquisition, ordering, storage, shipment, or sale of a basic model determined to be in noncompliance.

(2) The manufacturer may modify the noncompliant basic model in such manner as to make it comply with the applicable performance standard. The manufacturer or private labeler must treat such a modified basic model as a new basic model and certify it in accordance with the provisions of this subpart. In addition to satisfying all requirements of this subpart, the manufacturer must also maintain records that demonstrate that modifications have been made to all

units of the new basic model before its distribution in commerce.

(3) If a manufacturer or private labeler has a basic model that is not properly certified in accordance with the requirements of this subpart, the Secretary may seek, among other remedies, injunctive action to prohibit distribution in commerce of the basic model.

**Appendix A to Subpart S of Part 431— Compliance Statement for Metal Halide Lamp Ballasts**

Equipment: Metal Halide Lamp Ballasts  
Manufacturer's or Private Labeler's Name and Address:

[Company name] ("the company") submits this Compliance Statement under 10 CFR Part 431 (Energy Efficiency Program for Certain Commercial and Industrial Equipment) and Part A of the Energy Policy and Conservation Act (Pub. L. 94-163), and amendments thereto. I am signing this on behalf of and as a responsible official of the company. All basic models of metal halide lamp ballasts subject to energy conservation standards specified in 10 CFR Part 431 that this company manufactures comply with the applicable energy conservation standard(s). We have complied with the applicable testing requirements (prescribed in 10 CFR Part 431) in making this determination, and in determining the energy efficiency set forth in all Certification Reports submitted by or on behalf of this company. All information in such Certification Report(s) and in this Compliance Statement is true, accurate, and complete. The company pledges that all this information in any future Compliance Statement(s) and Certification Report(s) will meet these standards, and that the company will comply with the energy conservation requirements in 10 CFR Part 431 with regard to any new basic model it distributes in the future. The company is aware of the penalties associated with violations of the Act and the regulations thereunder, and is also aware of the provisions contained in 18 U.S.C. 1001, which prohibits knowingly making false statements to the Federal Government.

Name of Company Official: \_\_\_\_\_  
Signature of Company Official: \_\_\_\_\_  
Title: \_\_\_\_\_  
Firm or Organization: \_\_\_\_\_  
Date: \_\_\_\_\_  
Name of Person to Contact for Further Information: \_\_\_\_\_  
Address: \_\_\_\_\_  
Telephone Number: \_\_\_\_\_  
Facsimile Number: \_\_\_\_\_  
Email: \_\_\_\_\_  
Third-Party Representation (if applicable)  
For certification reports prepared and submitted by a third-party organization under the provisions of 10 CFR Part 431, the company official who authorized said third-party representation is:  
Name: \_\_\_\_\_  
Title: \_\_\_\_\_  
Address: \_\_\_\_\_

Telephone Number: \_\_\_\_\_  
Facsimile Number: \_\_\_\_\_  
Email: \_\_\_\_\_

The third-party organization authorized to act as representative:

Third-Party Organization: \_\_\_\_\_  
Address: \_\_\_\_\_  
Telephone Number: \_\_\_\_\_  
Facsimile Number: \_\_\_\_\_  
Email: \_\_\_\_\_

Submit by Certified Mail to: U.S. Department of Energy, Building Technologies Program, Mailstop EE-2J, 1000 Independence Avenue, SW, Washington, DC 20585-0121. Submit by e-mail in PDF format (which shows original signature) to the U.S. Department of Energy, Buildings Technologies Program at: [certification.report@ee.doe.gov](mailto:certification.report@ee.doe.gov).

**Appendix B to Subpart S to Part 431— Certification Report for Metal Halide Lamp Ballasts**

All information reported in this Certification Report(s) is true, accurate, and complete. The company is aware of the penalties associated with violations of the Act, the regulations thereunder, and is also aware of the provisions contained in 18 U.S.C. 1001, which prohibits knowingly making false statements to the Federal Government.

Name of Company Official or Third-Party Representative: \_\_\_\_\_

Signature of Company Official or Third-Party Representative: \_\_\_\_\_

Title: \_\_\_\_\_  
Date: \_\_\_\_\_  
Equipment Type: \_\_\_\_\_  
Manufacturer: \_\_\_\_\_  
Name of Person to Contact for Further Information: \_\_\_\_\_

Address: \_\_\_\_\_  
Telephone Number: \_\_\_\_\_  
Facsimile Number: \_\_\_\_\_  
E-mail: \_\_\_\_\_

For Existing, New, or Modified Models: [Provide specific equipment information including, for each basic model, the product class, the manufacturer's model number(s), and the other information required in 431.327(a)(6)(i).]

For Discontinued Models: [Provide manufacturer's model number(s).]

Submit by Certified Mail to: U.S. Department of Energy, Building Technologies Program, Mailstop EE-2J, 1000 Independence Avenue, SW., Washington, DC 20585-0121. Submit by E-mail to: U.S. Department of Energy, Buildings Technologies Program, [certification.report@ee.doe.gov](mailto:certification.report@ee.doe.gov).

**Appendix C to Subpart S of Part 431— Enforcement for Performance Standards; Compliance Determination Procedure for Metal Halide Lamp Ballasts**

DOE will determine compliance as follows:  
(a) After it has determined the sample size, DOE will measure the energy performance for each unit in accordance with the following table:



Sample size	Number of tests for each unit
4	1
3	1
2	2
1	4

(b) Compute the mean of the measured energy performance ( $x_1$ ) for all tests as follows:

$$x_1 = \frac{1}{n_1} \left\{ \sum_{i=1}^{n_1} x_i \right\} \quad [1]$$

Where  $x_i$  is the measured energy efficiency or consumption from test  $i$ , and  $n_1$  is the total number of tests.

(c) Compute the standard deviation ( $S_1$ ) of the measured energy performance from the  $n_1$  tests as follows:

$$S_1 = \sqrt{\frac{\sum_{i=1}^{n_1} (x_i - x_1)^2}{n_1 - 1}} \quad [2]$$

(d) Compute the standard error ( $S_{x_1}$ ) of the measured energy performance from the  $n_1$  tests as follows:

$$S_{x_1} = \frac{S_1}{\sqrt{n_1}} \quad [3]$$

(e)(1) For an energy efficiency standard, compute the lower control limit ( $LCL_1$ ) according to:

$$LCL_1 = EPS - ts_{x_1} \quad [4a]$$

or

$$LCL_1 = 97.5 \text{ EPS} \quad [4b]$$

(whichever is greater)

(2) For an energy use standard, compute the upper control limit ( $UCL_1$ ) according to:

$$UCL_1 = EPS + ts_{x_1} \quad [5a]$$

or

(whichever is less)

$$UCL_1 = 1.025 \text{ EPS} \quad [5b]$$

Where EPS is the energy performance standard and  $t$  is a statistic based on a 99-percent, one-sided confidence limit and a sample size of  $n_1$ .

(f)(1) Compare the sample mean to the control limit. The basic model is in compliance and testing is at an end if, for an energy efficiency standard, the sample mean is equal to or greater than the lower control limit or, for an energy consumption standard, the sample mean is equal to or less than the upper control limit. If, for an energy efficiency standard, the sample mean is less than the lower control limit or, for an energy consumption standard, the sample mean is

greater than the upper control limit, compliance has not been demonstrated. Unless the manufacturer requests manufacturer-option testing and provides the additional units for such testing, the basic model is in noncompliance, and the testing is at an end.

(2) If the manufacturer does request additional testing and provides the necessary additional units, DOE will test each unit the same number of times it tested previous units. DOE will then compute a combined sample mean, standard deviation, and standard error as described above. (The "combined sample" refers to the units DOE initially tested plus the additional units DOE has tested at the manufacturer's request.) DOE will determine compliance or noncompliance from the mean and the new lower or upper control limit of the combined sample. If, for an energy efficiency standard, the combined sample mean is equal to or greater than the new lower control limit or, for an energy consumption standard, the sample mean is equal to or less than the upper control limit, the basic model is in compliance and testing is at an end. If the combined sample mean does not satisfy one of these two conditions, the basic model is not in compliance.

[FR Doc. 2010-3841 Filed 3-8-10; 8:45 am]

**BILLING CODE 6450-01-P**